



EMBEDDED HACKING

FIRST EDITION 1.0001 IN-DEVELOPMENT-ALPHA

Copyright © 2025 Kevin Thomas

Forward

I remember when I started learning programming to which my first language was 6502 Assembler to allow me to program a Commodore 64 and right from the beginning of my journey, I learned the lowest level development possible.

Literally every piece of the Commodore 64 was understood as it was a simple machine. There was absolutely no abstraction layer of any kind.

We had an absolute mastery of everything however it was a very simple architecture.

Microcontrollers are small systems without an operating system and are also very simple in their design. They are literally everywhere from your toaster to your fridge to your TV and billions of other electronics that you never think about.

Most microcontrollers are developed in the C programming language which has its roots to the 1970's however dominates the landscape.

We will take our time and learn the basics of C utilizing a Pico 2 microcontroller.

Below are items you will need for this course.

Raspberry Pi Pico 2 w/ Header

<https://www.pishop.us/product/raspberry-pi-pico-2-with-header>

USB A-Male to USB Micro-B Cable

<https://www.pishop.us/product/usb-a-male-to-usb-micro-b-cable-6-inches>

Raspberry Pi Pico Debug Probe

<https://www.pishop.us/product/raspberry-pi-debug-probe>

Complete Component Kit for Raspberry Pi

<https://www.pishop.us/product/complete-component-kit-for-raspberry-pi>

NOTE: The item links may NOT be available, but the descriptions allow you to shop on any online or physical store of your choosing.

Let's begin...

Table Of Contents

Chapter 1:	hello, world
Chapter 2:	Debugging hello, world
Chapter 3:	Hacking hello, world
Chapter 4:	Embedded System Analysis
Chapter 5:	Intro To Variables
Chapter 6:	Debugging Intro To Variables
Chapter 7:	Hacking Intro To Variables
Chapter 8:	Uninitialized Variables
Chapter 9:	Debugging Uninitialized Variables
Chapter 10:	Hacking Uninitialized Variables
Chapter 11:	Integer Data Type
Chapter 12:	Debugging Integer Data Type
Chapter 13:	Hacking Integer Data Type
Chapter 14:	Floating-Point Data Type
Chapter 15:	Debugging Floating-Point Data Type
Chapter 16:	Hacking Floating-Point Data Type
Chapter 17:	Double Floating-Point Data Type
Chapter 18:	Debugging Double Floating-Point Data Type
Chapter 19:	Hacking Double Floating-Point Data Type
Chapter 20:	Static Variables
Chapter 21:	Debugging Static Variables
Chapter 22:	Hacking Static Variables
Chapter 23:	Constants
Chapter 24:	Debugging Constants
Chapter 25:	Hacking Constants
Chapter 26:	Operators
Chapter 27:	Debugging Operators
Chapter 28:	Hacking Operators
Chapter 29:	Static Conditionals
Chapter 30:	Debugging Static Conditionals
Chapter 31:	Hacking Static Conditionals
Chapter 32:	Dynamic Conditionals
Chapter 33:	Debugging Dynamic Conditionals
Chapter 34:	Hacking Dynamic Conditionals
Chapter 35:	Functions, w/o Param, w/o Return
Chapter 36:	Debugging Functions, w/o Param, w/o Return
Chapter 37:	Hacking Functions, w/o Param, w/o Return
Chapter 38:	Functions, w/ Param, w/ Return
Chapter 39:	Debugging Functions, w/ Param, w/ Return
Chapter 40:	Hacking Functions, w/ Param, w/ Return

Chapter 1: hello, world

We begin our journey building the traditional *hello, world* example in Embedded C.

Below we see our diagrams for the Pico Debug Probe and our breadboard schematic which includes our Pico 2 microcontroller.

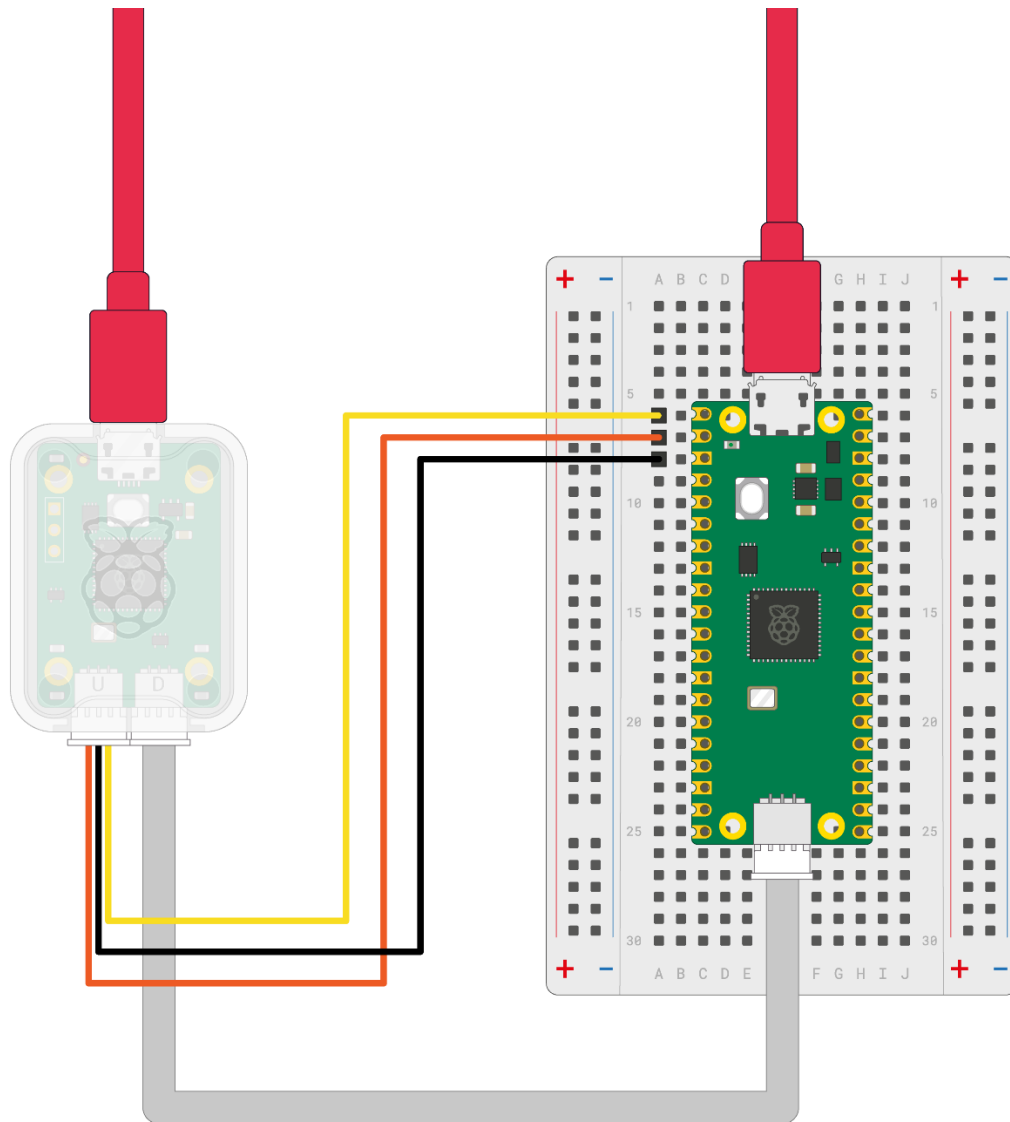

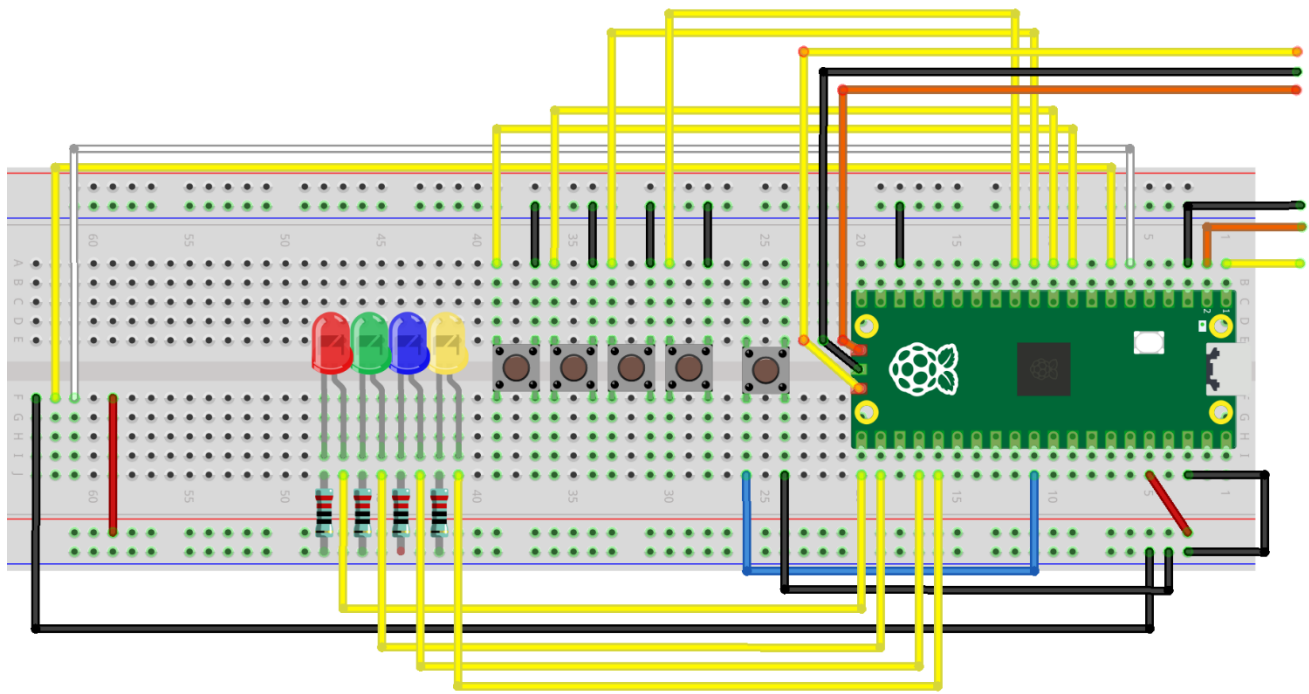

fritzing

To setup our development environment, we will download VS Code.

<https://code.visualstudio.com/download>

Once VS Code is installed, we will install the Raspberry Pi Pico VS Code extension.

<https://marketplace.visualstudio.com/items?itemName=raspberry-pi.raspberry-pi-pico>

We will setup the Raspberry Pi Pico Debug Probe as there are detailed instructions below as well to get started.

<https://www.raspberrypi.com/documentation/microcontrollers/debug-probe.html>

A pinout of the Pico 2 board is linked below as well.

<https://www.raspberrypi.com/documentation/microcontrollers/images/pico-2-r4-pinout.svg>

If you do not have Git installed, here is a link to install git on Windows, MAC and Linux.

<https://git-scm.com/book/en/v2/Getting-Started-Installing-Git>

We need to clone our course repo to whatever folder you prefer.

```
git clone https://github.com/mytechtalent/Embedded-Hacking.git
```

Open VS Code and click **File** then **Open Folder** then click on the **Embedded-Hacking** folder and then select **0x0001_hello-world**.

This may pop up a screen asking to import the project. Once visible, click **Import**, otherwise just continue.

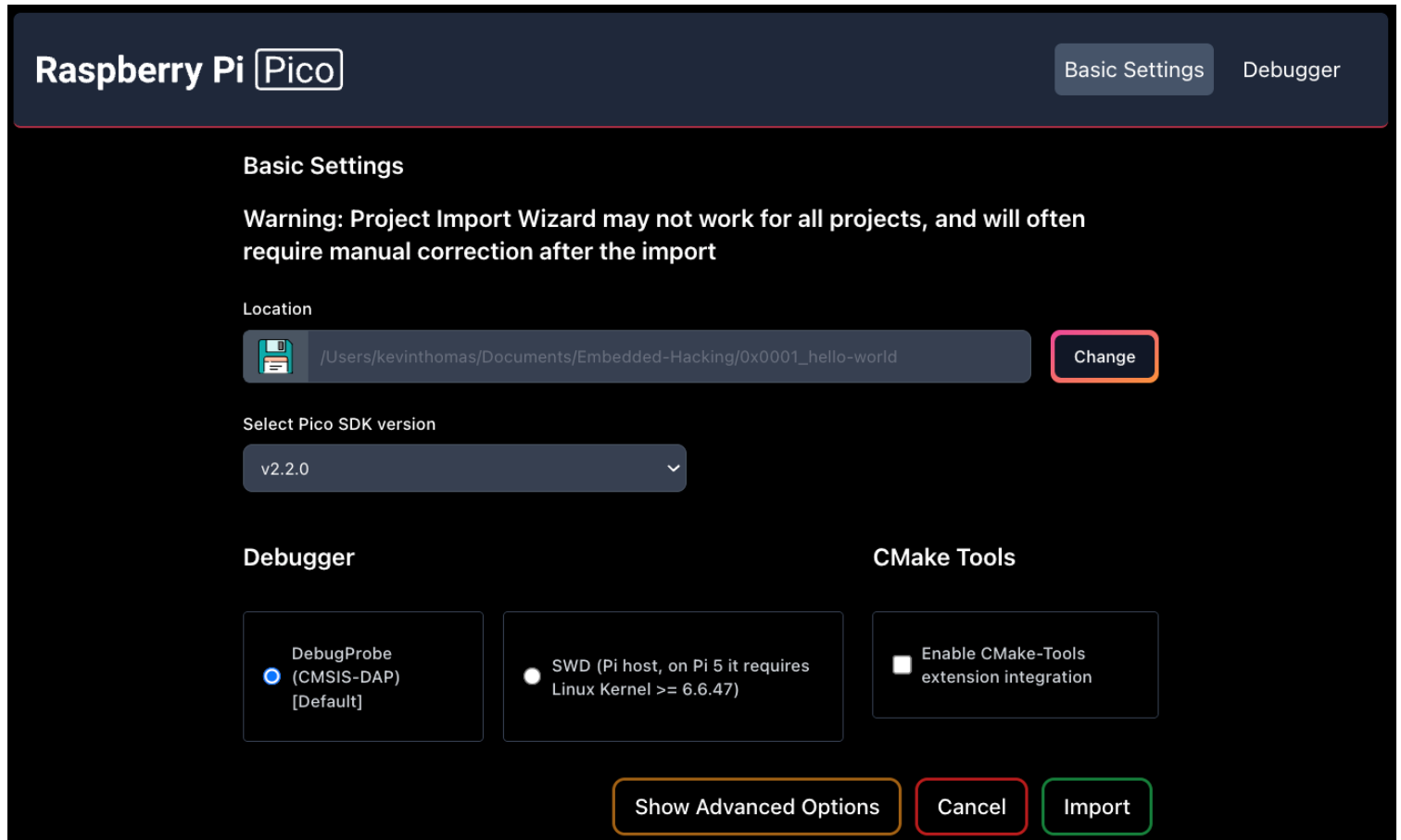

Now we are ready to compile and flash our code onto the Pico.

You can click on **Compile** and then **Run** in the bottom right-hand side of the VS Code editor assuming you have your Pico 2 plugged in.

Press and hold the push button we attached to the breadboard while pressing the white BOOTSEL button on the Pico 2; then release the white BOOTSEL button on the Pico 2 and then release the push button we attached to the breadboard.

If the **Compile** and **Run** buttons within VS Code does not work, you can also open a file explorer window to copy our **0x0001_hello-world.uf2** firmware into the **RPI-RP2** drive.

We need to download a serial monitor to interact with our Pico. If you are on Windows download PuTTY as the link is below.

<https://www.putty.org>

If you are on Windows, you can open the Device Manager and look for the COM port that will be used to connect PuTTY to. There are at minimum two ports one for the Pico 2 UART and the other for the Pico Debug Probe. Try both and one of them will be UART that we are looking for.



The next step is to run PuTTY.

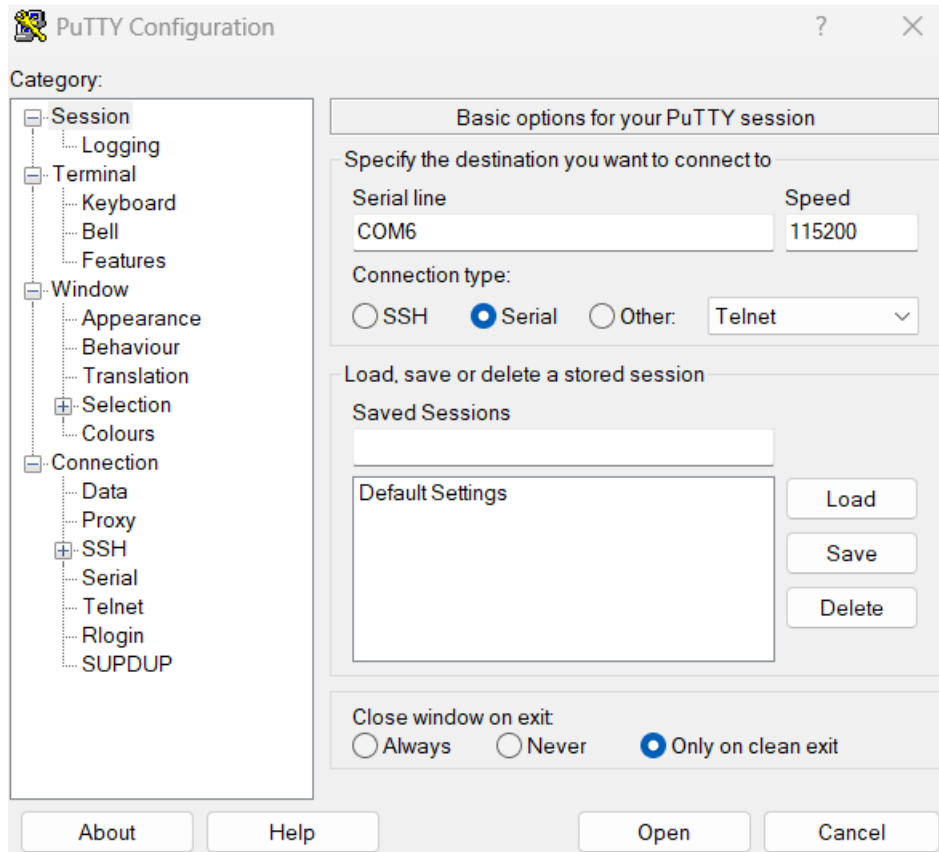

You want to type in your COM port, in my case COM6, and click the **Open** button.

If you are on MAC or Linux, you can use the screen program.

```
ls /dev/tty.  
screen /dev/tty.XXX 115200
```

Now let's review our **0x0001_hello-world.c** file as this is located within the main folder.

```
#include <stdio.h>  
#include "pico/stdlib.h"  
  
int main(void) {  
    stdio_init_all();  
  
    while (true)  
        printf("hello, world\r\n");  
}
```

Let's break down this code.

```
#include <stdio.h>
```

This line includes the `stdio.h` header file, which contains declarations for standard input and output functions.

```
#include "pico/stdlib.h"
```

This line includes the `pico/stdlib.h` header file, which contains declarations for various Raspberry Pi Pico standard library functions.

```
int main(void)
```

The above line declares the main function, which is the entry point for all C and Python programs.

```
stdio_init_all();
```

This line initializes the standard input and output system.

```
while (true)
```

This line starts a while loop that will run forever.

```
printf("hello, world\r\n");
```

This line prints the message, *hello, world*, to the console.

Open the terminal to see, *hello, world*, as expected being printed over and over again.

Chapter 2: Debugging hello, world

Today we debug!

There are two main types of reverse engineering: static and dynamic. Static reverse engineering involves examining the binary without executing it. Tools like Ghidra allow you to inspect raw assembly instructions, control flow, and code structure. Dynamic reverse engineering, on the other hand, involves running the binary and observing its behavior in real time. With tools like GDB, you can monitor memory changes, register values, and execution paths as the program runs.

We will download Ghidra, a free static disassembler from the NSA at the link below.

<https://github.com/NationalSecurityAgency/ghidra/releases>

If you are using Windows, we will move the Ghidra folder to the **C:** drive and make sure to update the path accordingly. If you are on MAC or Linux, move to the root of your drive as well and update version in path.

`C:\ghidra_11.4.2_PUBLIC`

Please download and install the proper Java version based on your system.

<https://adoptium.net/temurin/releases>

Once complete, a file called **ghidraRun** will be created. To launch Ghidra, execute this file. If you're on Windows, be sure to run the batch file version.

A window will appear where we will select **File, New Project, Non-Shared Project, Next**, and create a **Project Name**. Here we will call it **0x0001_hello-world** and press **Finish**.

Open the file explorer and navigate to the **Embedded-Hacking** folder and drag-and-drop the **0x0001_hello-world.elf** file into the folder within the Ghidra application panel.

In the small window that appears, you will see the file identified as an ELF, which stands for Executable and Linkable Format. This format includes symbols that make reverse engineering easier. In future chapters, we will work with stripped binaries that do not contain these symbols.

At this point, click **Ok** and then double-click on the file within the window.

Finally click the auto-analyze and let's begin reviewing the binary.

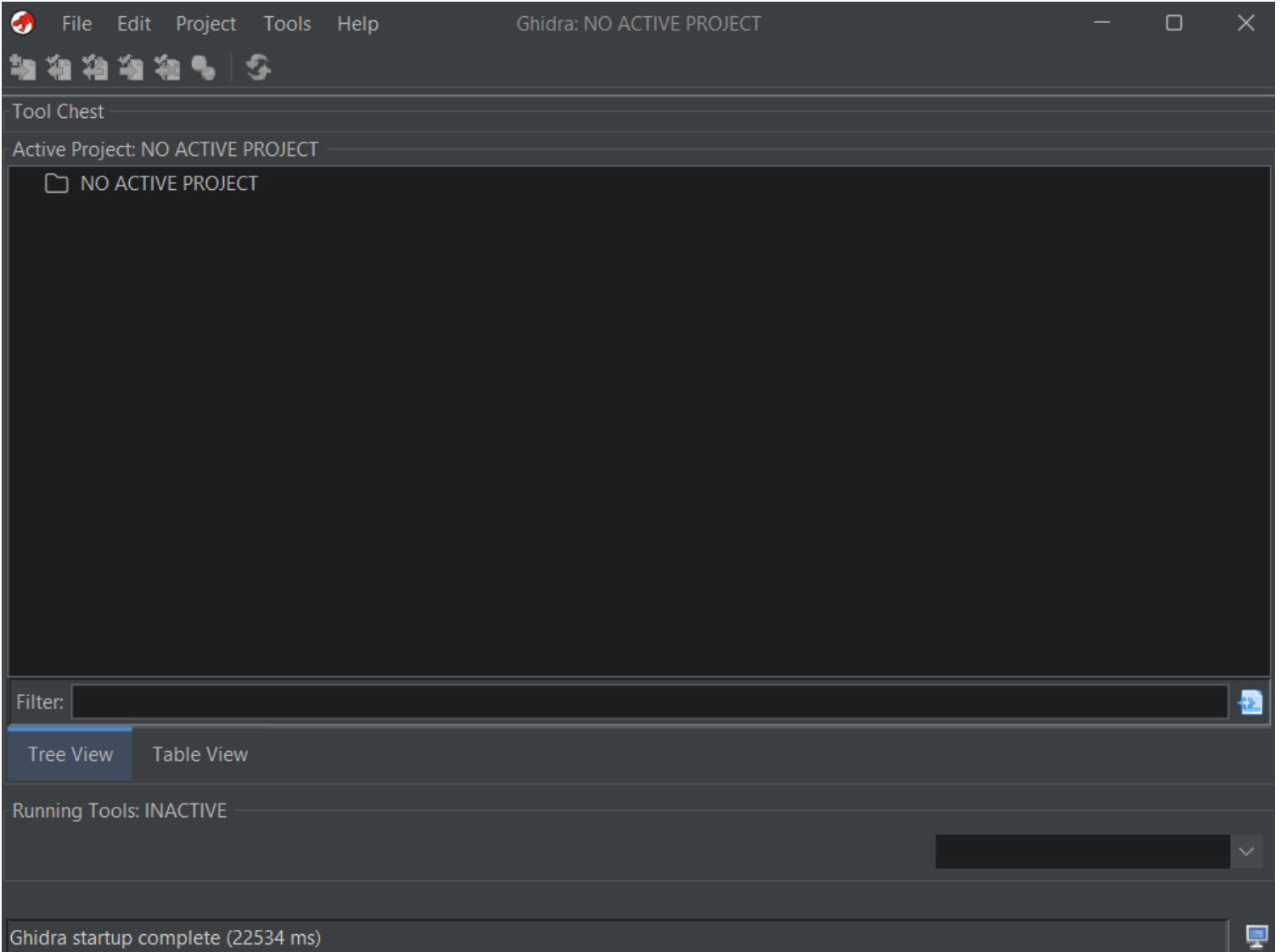

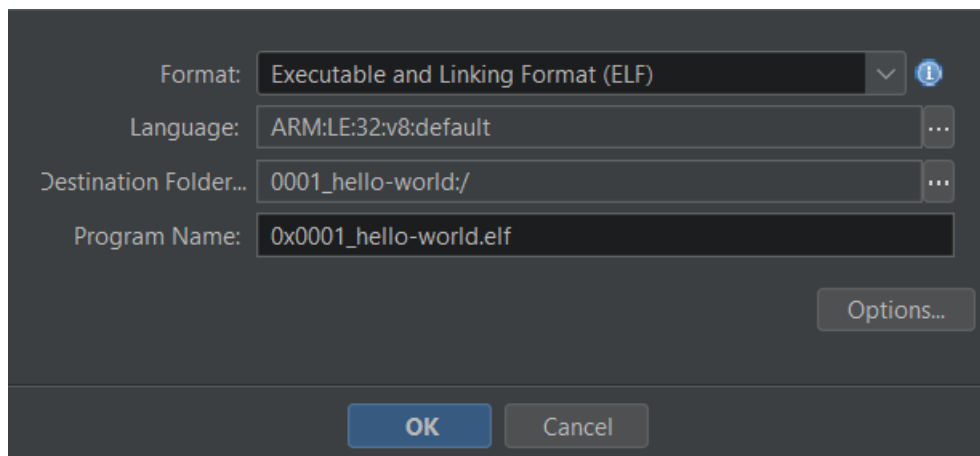
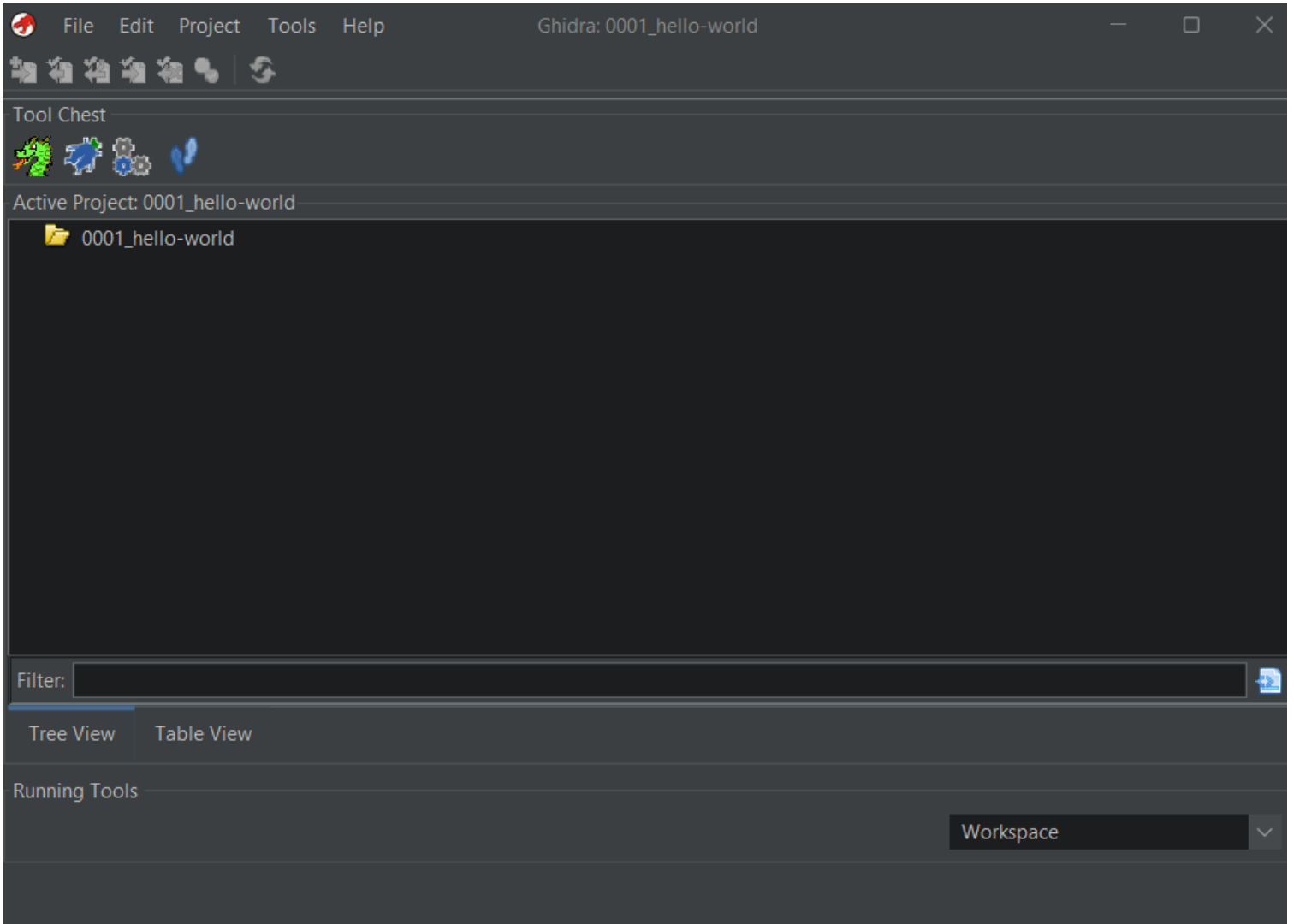

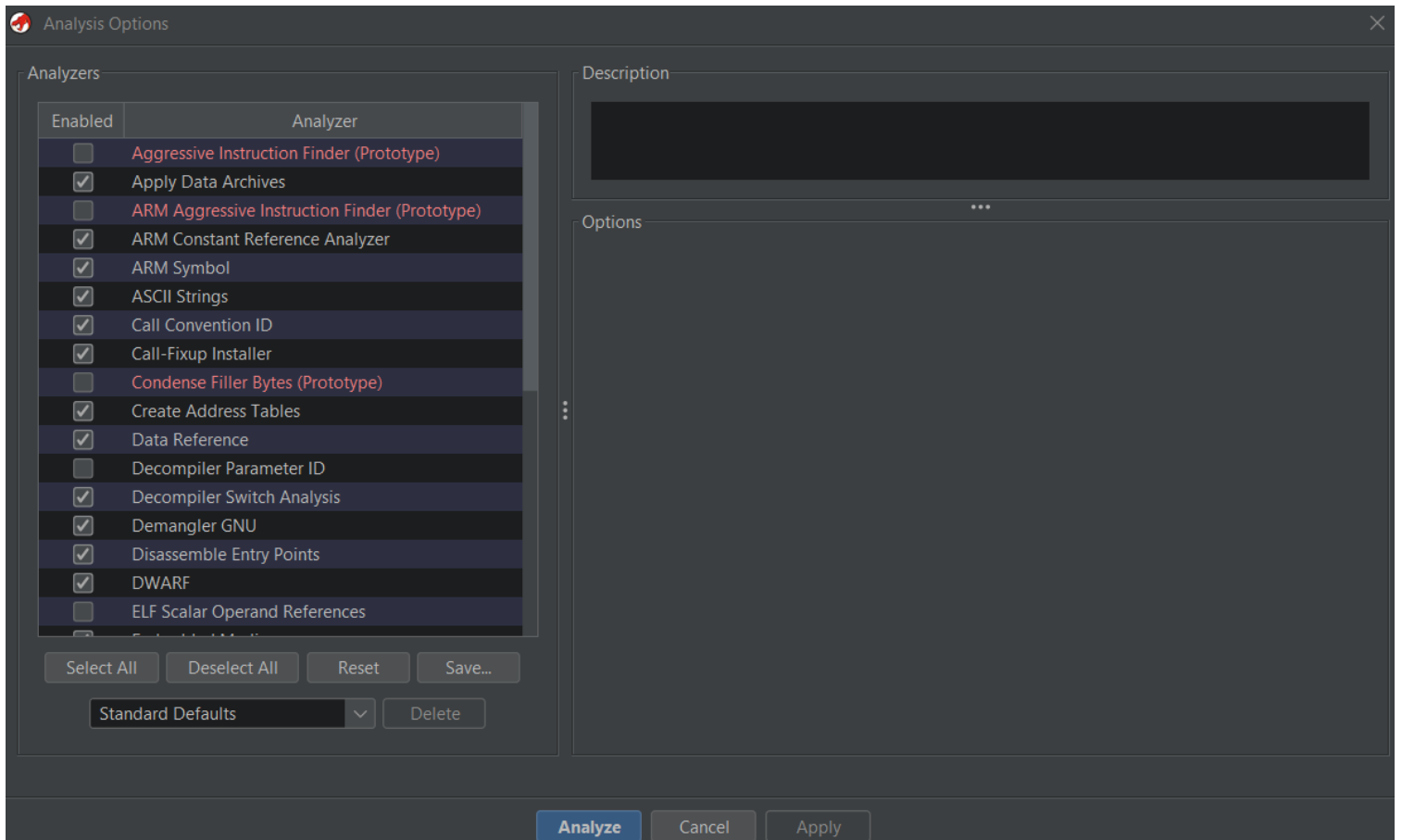
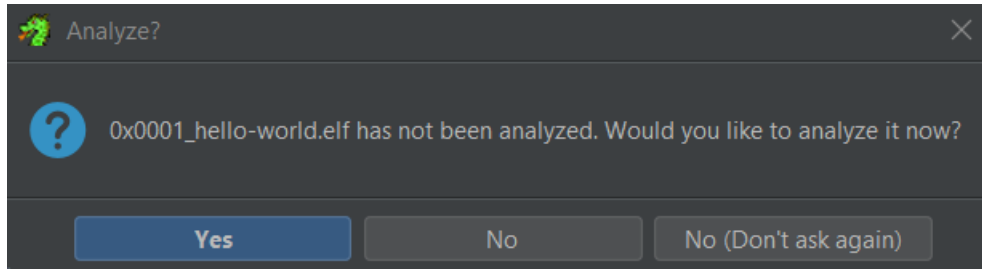

```

*****
*
*                               FUNCTION                               ...
*****
int main(void)
    assume LRset = 0x0
    assume TMode = 0x1
int      r0:4      <RETURN>
main          XREF[3]:  Entry Point(*),
                _reset_handler:1000018c(c),
                .debug_frame::00000018(*)
0x0001_hello-world.c:4 (2)
0x0001_hello-world.c:5 (2)
10000234 08 b5      push      {r3,lr}
                0x0001_hello-world.c:5 (4)
10000236 01 f0 99 f9  bl      _Bool stdio_init_all(void)
                LAB_1000023a          XREF[1]:  10000240(j)
                0x0001_hello-world.c:7 (6)
                0x0001_hello-world.c:8 (6)
1000023a 02 48      ldr      r0=>__EH_FRAME_BEGIN__, [DAT_10000244] = "hello, world\r"
                = 100019CCh
1000023c 01 f0 de f9  bl      __wrap_puts      int __wrap_puts(char * s)
                0x0001_hello-world.c:7 (8)
10000240 fb e7      b      LAB_1000023a
10000242 00      ??      00h
10000243 bf      ??      BFh

```

```

1
2 /* WARNING: Unknown calling convention */
3
4 int main(void)
5
6 {
7     stdio_init_all();
8     do {
9         __wrap_puts("hello, world\r");
10    } while( true );
11 }
12

```

I have held off on exploring the deeper meaning behind all of this because our first goal is to establish a solid static reverse engineering workflow.

Now we can see our main function displayed in raw assembly, a decompiled view, and a pseudo source code window.

One of the first differences we notice is that our original source used a while true loop, but the decompiled output shows a do while loop. This is not a major issue, as the logic is still clear and we can see the code echoing *hello, world* to the terminal.

In our original source, we used the `printf` function. After compilation, the compiler optimized this and replaced it with the `puts` function, which is a common substitution for simple output.

At this point, I am going to pause on reviewing the assembly and shift focus to setting up GDB. This will allow us to begin dynamic reverse engineering, along with a basic introduction to the ARM architecture we are working with.

To enable dynamic reverse engineering capabilities, we will download the GNU ARM toolchain tailored to our embedded architecture. Be sure to select the version appropriate for your system.

<https://developer.arm.com/downloads/-/arm-gnu-toolchain-downloads>

The next step is to download OpenOCD. If you are on Windows, there are pre-build binaries at the location below.

<https://gnutoolchains.com/arm-eabi/openocd>

If you are on Windows, the next step is to extract the folder to your `C:\` drive and update your path to include the following directories and keep in mind the version you downloaded as you may need to adjust the path.

```
C:\OpenOCD-20250710-0.12.0\bin
C:\OpenOCD-20250710-0.12.0\share\openocd\scripts\interface
C:\OpenOCD-20250710-0.12.0\share\openocd\scripts\target
```

For MAC, we first install Homebrew and the various dependencies and OpenOCD.

```
/bin/bash -c "$(curl -fsSL
https://raw.githubusercontent.com/Homebrew/install/HEAD/install.sh)"
brew install git libtool automake pkg-config libusb
brew install openocd
```

For Linux, we install the various dependencies and OpenOCD.

```
sudo apt update
sudo apt install git build-essential libtool autoconf pkg-config libusb-1.0-0-dev
libftd2rl-dev
sudo apt install openocd
```

Run OpenOCD with the below config.

```
openocd -f interface/cmsis-dap.cfg -f target/rp2350.cfg -c "adapter speed 5000"
```

Open a new terminal and then run the following to launch our dynamic debugger called GDB.

```
arm-none-eabi-gdb build/0x0001_hello-world.elf
```

Once it loads, we need to target our remote server.

```
target remote :3333
```

We need to halt the currently running binary.

```
monitor reset halt
```

```
C:\Users\assem.KEVINTHOMAS\Documents\Embedded-Hacking\0x0001_hello-world>arm-none-eabi-gdb build\0x0001_hello-world.elf
GNU gdb (Arm GNU Toolchain 14.3.Rel1 (Build arm-14.174)) 15.2.90.20241229-git
Copyright (C) 2024 Free Software Foundation, Inc.
License GPLv3+: GNU GPL version 3 or later <http://gnu.org/licenses/gpl.html>
This is free software: you are free to change and redistribute it.
There is NO WARRANTY, to the extent permitted by law.
Type "show copying" and "show warranty" for details.
This GDB was configured as "--host=x86_64-w64-mingw32 --target=arm-none-eabi".
Type "show configuration" for configuration details.
For bug reporting instructions, please see:
<https://bugs.linaro.org/>.
Find the GDB manual and other documentation resources online at:
  <http://www.gnu.org/software/gdb/documentation/>.

For help, type "help".
Type "apropos word" to search for commands related to "word"...
Reading symbols from build\0x0001_hello-world.elf...
(gdb) target remote :3333
Remote debugging using :3333
uart_tx_wait_blocking (uart=warning: could not convert 'uart_inst' from the host encoding (CP1252) to UTF-32.
This normally should not happen, please file a bug report.
0x40070000)
   at C:/Users/assem.KEVINTHOMAS/.pico-sdk/sdk/2.2.0/src/rp2_common/hardware_uart/include/hardware_uart.h:432
432   while (uart_get_hw(uart)->fr & UART_UARTFR_BUSY_BITS) tight_loop_contents();
(gdb) monitor reset halt
[rp2350.cm0] halted due to debug-request, current mode: Thread
xPSR: 0xf9000000 pc: 0x00000088 msp: 0xf0000000
[rp2350.cm1] halted due to debug-request, current mode: Thread
xPSR: 0xf9000000 pc: 0x00000088 msp: 0xf0000000
(gdb)
```

Before we go any further, we need to turn to the RP2350 datasheet.

<https://datasheets.raspberrypi.com/rp2350/rp2350-datasheet.pdf>

2.2. Address map

The address map for the device is split into sections as shown in [Table 8](#). Details are shown in the following sections. Unmapped address ranges raise a bus error when accessed.

Each link in the left-hand column of [Table 8](#) goes to a detailed address map for that address range. The detailed address maps have a link for each address to the relevant documentation for that address.

Rough address decode is first performed on bits 31:28 of the address:

Table 8. Address Map Summary

Bus Segment	Base Address
ROM	0x00000000
XIP	0x10000000
SRAM	0x20000000
APB Peripherals	0x40000000
AHB Peripherals	0x50000000
Core-local Peripherals (SIO)	0xd0000000
Cortex-M33 private registers	0xe0000000

Above is page 30 where we see our address map.

XIP, a technique where firmware instructions are executed directly from non-volatile memory rather than being copied into RAM.

Table 10. Address map for XIP bus segment

Bus Endpoint	Base Address
XIP_BASE	0x10000000
XIP_NOCACHE_NOALLOC_BASE	0x14000000
XIP_MAINTENANCE_BASE	0x18000000
XIP_NOCACHE_NOALLOC_NOTRANSLATE_BASE	0x1c000000

At address 0x10000000, is where we will focus within GDB.

Before we dive into the assembler, we need to understand we are working with an RP2350 microcontroller that has a dual-core architecture.

This course will not focus on the RISC-V core however will focus on the ARM Cortex-M33 core as this is more prevalent in the industry today however a future course may cover the RISC-V core.

The ARM Cortex-M33 core is part of what we refer to as the Armv8-M Mainline family. We will review the Arm Cortex-M33 Processor Technical Reference Manual that is included in the course Github repo.

Name	Description
R0-R12	R0-R12 are general-purpose registers for data operations.
MSP (R13)	The <i>Stack Pointer</i> (SP) is register R13. In Thread mode, the CONTROL register indicates the stack pointer to use, <i>Main Stack Pointer</i> (MSP) or <i>Process Stack Pointer</i> (PSP).
PSP (R13)	When the Armv8-M Security Extension is included, there are two MSP registers in the Cortex-M33 processor: <ul style="list-style-type: none"> • MSP_NS for the Non-secure state. • MSP_S for the Secure state. When the Armv8-M Security Extension is included, there are two PSP registers in the Cortex-M33 processor: <ul style="list-style-type: none"> • PSP_NS for the Non-secure state. • PSP_S for the Secure state.
MSPLIM	The stack limit registers limit the extent to which the MSP and PSP registers can descend respectively.
PSPLIM	When the Armv8-M Security Extension is included, there are two MSPLIM registers in the Cortex-M33 processor: <ul style="list-style-type: none"> • MSPLIM_NS for the Non-secure state. • MSPLIM_S for the Secure state. When the Armv8-M Security Extension is included, there are two PSPLIM registers in the Cortex-M33 processor: <ul style="list-style-type: none"> • PSPLIM_NS for the Non-secure state. • PSPLIM_S for the Secure state.
LR (R14)	The <i>Link Register</i> (LR) is register R14. It stores the return information for subroutines, function calls, and exceptions.
PC (R15)	The <i>Program Counter</i> (PC) is register R15. It contains the current program address.
PSR	The <i>Program Status Register</i> (PSR) combines: <ul style="list-style-type: none"> • <i>Application Program Status Register</i> (APSR). • <i>Interrupt Program Status Register</i> (IPSR). • <i>Execution Program Status Register</i> (EPSR). These registers provide different views of the PSR.

On page B1-40, we see the above processor core register summary.

Our microcontroller has 13 general-purpose 32-bit wide registers called r_0-r_{12} . These registers will be used for storing intermediate values, passing function arguments, and performing arithmetic or logical operations during program execution. They form the core working set for most instructions and are essential for efficient data manipulation and control flow within the processor.

The r_{13} register is called the stack pointer. The stack pointer holds the address of the top of the stack, a region of memory used for temporary storage during function calls. When a function is called, local variables,

return addresses, and saved register states are pushed onto the stack. As the function exits, these values are popped off. The stack grows downward in memory on ARM Cortex-M systems, and the `sp` ensures that data is stored and retrieved in the correct order. It's critical for managing nested function calls and interrupt handling.

The `r14` register is called the link register. The link register stores the return address when a function or subroutine is called. In ARM assembly, instructions like `bl` (Branch with Link) automatically place the address of the next instruction into `lr` so the processor knows where to return after the function finishes. If `lr` is overwritten or mishandled, the program may jump to an unintended location, leading to crashes or undefined behavior. In exception handling, `lr` also plays a role in determining the return path after servicing an interrupt.

The `r15` register is called the program counter. The program counter holds the address of the next instruction to be executed. It's automatically updated as the processor steps through instructions, and can be manually modified during jumps, branches, or exceptions. The `pc` is central to control flow, whether you're executing sequential code, branching conditionally, or handling interrupts. In debugging or reverse engineering, tracking the `pc` helps you understand exactly where the processor is in its execution lifecycle.

We need to touch base on what XIP is within the RP2350 MCU microcontroller. This is the actual chip that powers the Pico 2.

As mentioned earlier, XIP is called, execute in place, and is capable of directly executing code from non-volatile storage (such as flash memory) without the need to copy the code to random-access memory (RAM) first. Instead of loading the entire program into RAM, XIP systems fetch instructions directly from their storage location and execute them on the fly.

Our goal is to find the main function within our binary to reverse engineer it. Before our main function there will be a large amount of setup code to include the vector table which will handle hardware interrupts and exceptions within our firmware which will be at the address close to the beginning of `0x10000000`.

Our XIP address starts at `0x10000000` so let's examine 1000 instructions and look for a `push {r3, lr}` followed by a call to `stdio_init_all` which would indicate our main stack frame being called.

```
(gdb) x/1000i 0x10000000
...
0x10000234 <main>:  push    {r3, lr}
...
```

This is our main program. If you are new to assembler, do not be discouraged as we will take this step-by-step!

To begin working effectively with the RP2350, it is important to understand how memory is organized within the microcontroller. The RP2350 features a dual-core ARM Cortex-M33 processor, which introduces more advanced memory management capabilities compared to earlier architectures. We start by examining the stack and heap, as these are essential concepts in embedded systems.

The stack is a region of memory used to manage function calls and local variables. It automatically grows and shrinks as functions are called and return. Each time a function is invoked, a stack frame is created to store its local variables and the return address. The stack pointer register keeps track of the current position in the stack and is updated automatically during function calls and returns.

Because the RP2350 has two cores, each core maintains its own dedicated stack. The size of each stack is typically defined in the linker script or project configuration and is constrained by the available RAM. When data is added to the stack, such as function parameters, it is referred to as a push operation. When data is removed, such as return values or saved registers, it is called a pop operation.

If the stack grows beyond its allocated space, it can result in a stack overflow. This may cause unpredictable behavior or system crashes. In contrast, the heap is a region of memory used for dynamic allocation. It is managed manually by the programmer, who must explicitly allocate and free memory as needed.

Dynamic memory allocation is performed using functions such as `malloc` in C or `new` in C++. This approach is useful for handling data structures whose size may vary during runtime. The heap in the RP2350 is typically located in the RAM region. Its size is flexible and can be adjusted based on the needs of the application.

Memory on the heap can be allocated to obtain a block of space and deallocated to return it for reuse. Over time, repeated allocation and deallocation can lead to fragmentation, which makes it harder to find large contiguous blocks of memory. The RP2350 uses standard C library functions such as `malloc` and `free` to manage heap memory. The size and location of the heap are usually defined in the linker script or project settings.

In this course, we will not necessarily focus on dynamic memory allocation. Instead, we will use safer and more predictable strategies for managing memory. The RP2350 has a limited amount of RAM, so careful planning is essential. Code is stored in Flash memory and is executed directly from that location. Understanding this memory layout is key to building reliable and efficient embedded applications.

Now let's examine our main function.

```
(gdb) x/5i 0x10000234
0x10000234 <main>:   push    {r3, lr}
0x10000236 <main+2>:   bl      0x1000156c <stdio_init_all>
0x1000023a <main+6>:   ldr     r0, [pc, #8]    @ (0x10000244 <main+16>)
0x1000023c <main+8>:   bl      0x100015fc <__wrap_puts>
0x10000240 <main+12>:  b.n     0x1000023a <main+6>
```

Let's set a breakpoint to our main function and continue.

```
(gdb) b *0x10000234
Breakpoint 1 at 0x10000234: file C:/Users/assem.KEVINTHOMAS/Documents/Embedded-
Hacking/0x0001_hello-world/0x0001_hello-world.c, line 5.
Note: automatically using hardware breakpoints for read-only addresses.
(gdb) c
Continuing.
Thread 1 "rp2350.cm0" hit Breakpoint 1, main ()
    at C:/Users/assem.KEVINTHOMAS/Documents/Embedded-Hacking/0x0001_hello-
world/0x0001_hello-world.c:5
```

```
warning: Source file is more recent than executable.
5         stdio_init_all();
```

Let's re-examine our main function and we will see an arrow pointing to the instruction we are about to execute. Keep in mind, we have NOT executed it yet.

```
(gdb) x/5i 0x10000234
=> 0x10000234 <main>:  push    {r3, lr}
0x10000236 <main+2>:  bl      0x1000156c <stdio_init_all>
0x1000023a <main+6>:  ldr    r0, [pc, #8]    @ (0x10000244 <main+16>)
0x1000023c <main+8>:  bl      0x100015fc <__wrap_puts>
0x10000240 <main+12>: b.n     0x1000023a <main+6>
```

We push the `r3` register and the `lr` register to the stack.

Keep in mind, the base pointer is not a register in the RP2350's ARM Cortex-M33 architecture. Unlike some other architectures such as x86, which use a dedicated base pointer for stack frame management, the Cortex-M33 relies on the stack pointer and the link register to handle function calls and returns.

In this architecture, the stack pointer, also known as `sp` or `r13`, points to the top of the stack and is automatically adjusted as functions are called and return. The link register, referred to as `lr` or `r14`, holds the return address when a function is invoked. These two registers work together to manage the stack and control program flow during subroutine execution.

The concept of a base pointer, as seen in x86/64 systems with the `RBP` register, is not part of the standard conventions used in the RP2350. Instead, stack frames are managed directly through `sp` and `lr` without a separate frame pointer.

It is important to note that in microcontroller environments like the RP2350, the main function typically runs in an infinite loop and does not return. As a result, the value stored in the link register after main begins execution is never used, but it remains part of the standard calling convention.

We have not executed our first main assembler function yet so let's first examine what our stack contains.

```
(gdb) x/10x $sp
0x20082000:  0x00000000    0x00000000    0x00000000    0x00000000
0x20082010:  0x00000000    0x00000000    0x00000000    0x00000000
0x20082020:  0x00000000    0x00000000
```

Now let's step-into which means take a single step in assembler.

```
(gdb) si
0x10000236    5          stdio_init_all();
(gdb) x/5i 0x10000234
0x10000234 <main>:  push    {r3, lr}
=> 0x10000236 <main+2>:  bl      0x1000156c <stdio_init_all>
0x1000023a <main+6>:  ldr    r0, [pc, #8]    @ (0x10000244 <main+16>)
0x1000023c <main+8>:  bl      0x100015fc <__wrap_puts>
```

```
0x10000240 <main+12>:      b.n      0x1000023a <main+6>
```

Let's review our stack.

```
(gdb) x/10x $sp
0x20081ff8:      0xe000ed08      0x1000018f      0x00000000      0x00000000
0x20082008:      0x00000000      0x00000000      0x00000000      0x00000000
0x20082018:      0x00000000      0x00000000
```

We can see that we have two new addresses that were pushed onto our stack.

To prove this, let's look at the values of `r3` and `lr`.

```
(gdb) x/x $r3
0xe000ed08:      Cannot access memory at address 0xe000ed08
(gdb) x/x $lr
0x1000018f <platform_entry+8>:  0x00478849
(gdb) x/x $sp
0x20081ff8:      0xe000ed08
```

The stack pointer is currently at address `0x20081ff8`, and the value at that location is `0xe000ed08`, which matches the value in `r3`. This suggests that `r3` was pushed onto the stack first.

```
(gdb) x/x $sp+4
0x20081ffc:      0x1000018f
```

We find the value `0x1000018f`, which matches the value in the link register. This confirms that the link register was pushed onto the stack after `r3`.

Because the stack grows downward in memory, each push operation moves the stack pointer to a lower address. The original stack pointer was at `0x20082000`, and after pushing two values, it moved down to `0x20081ff8`.

This behavior aligns with ARM calling conventions. During a function prologue, registers such as `lr` and any callee-saved registers are pushed onto the stack to preserve their values. The stack pointer is adjusted accordingly, and the return address stored in `lr` ensures that control can return to the correct location once the function completes.

I hope this helps you understand how the stack works. We will continue to examine the stack throughout this course.

Let's step-over the next instruction as it is a call to our below C- SDK function which is not of interest to as it simply sets up the MCU peripherals to communicate.

Our next step is to step-over the call to standard IO initialize all.

```
(gdb) x/5i 0x10000234
```

```

0x10000234 <main>:  push    {r3, lr}
=> 0x10000236 <main+2>: bl      0x1000156c <stdio_init_all>
0x1000023a <main+6>: ldr     r0, [pc, #8]    @ (0x10000244 <main+16>)
0x1000023c <main+8>: bl      0x100015fc <__wrap_puts>
0x10000240 <main+12>: b.n     0x1000023a <main+6>
(gdb) n
8      printf("hello, world\r\n");
(gdb) x/5i 0x10000234
0x10000234 <main>:  push    {r3, lr}
0x10000236 <main+2>: bl      0x1000156c <stdio_init_all>
=> 0x1000023a <main+6>: ldr     r0, [pc, #8]    @ (0x10000244 <main+16>)
0x1000023c <main+8>: bl      0x100015fc <__wrap_puts>
0x10000240 <main+12>: b.n     0x1000023a <main+6>

```

Now we are about to load the value **INSIDE** of a memory address at 0x10000244 into r0. The r0, [pc, #8] means take the value at the current program counter and add 8 to it and take that address's value and store it into r0. This is a pointer which means we are pointing to the value inside that address.

Let's *si* one step and examine what is inside r0 at this point.

```

(gdb) si
0x1000023c      8      printf("hello, world\r\n");
(gdb) x/x $r0
0x100019cc:      0x6c6c6568

```

Hmm... This does not look like an address however it does look like ascii chars to me. Let's look at an ascii table.

<https://www.asciitable.com>

We see 0x6c is l and we see it again so another l and 0x65 is e and 0x68 is h.

This is our *hello, world* string however it is backward! The reason is memory is stored in reverse byte order or little-endian order from memory to registers within the MCU.

We can see the full pointer to this char array or string by doing the below.

```

(gdb) x/s $r0
0x100019cc:      "hello, world\r"

```

In this chapter, we established a foundational reverse engineering workflow using both static and dynamic techniques. Through Ghidra, we examined the binary statically, observing the raw assembly and decompiled views to understand control flow and compiler optimizations. We noted subtle differences between our original source code and the decompiled output, such as the transformation of a `while (true)` loop into a `do-while` construct and the substitution of `printf` with `puts` for efficiency.

Using GDB, we transitioned into dynamic analysis, inspecting live register values and stack behavior during execution. We confirmed how the stack grows downward, how the link register is pushed to preserve return addresses, and how memory inspection reveals the inner workings of function calls. These observations aligned with ARM Cortex-M33 calling conventions and gave us a practical view of how the RP2350 handles execution at the instruction level.

Although the example was simple, it demonstrated the power of combining static and dynamic reverse engineering to gain insight into compiled binaries. With this workflow in place, we are now prepared to tackle more complex binaries, explore deeper architectural features of the RP2350, and refine our debugging strategies for embedded development.

In our next chapter we will hack this simple binary.

Chapter 3: Hacking hello, world

Today we hack!

Let's run OpenOCD to get our remote debug server going.

Let's run our serial monitor and observe *hello, world* in the infinite loop.

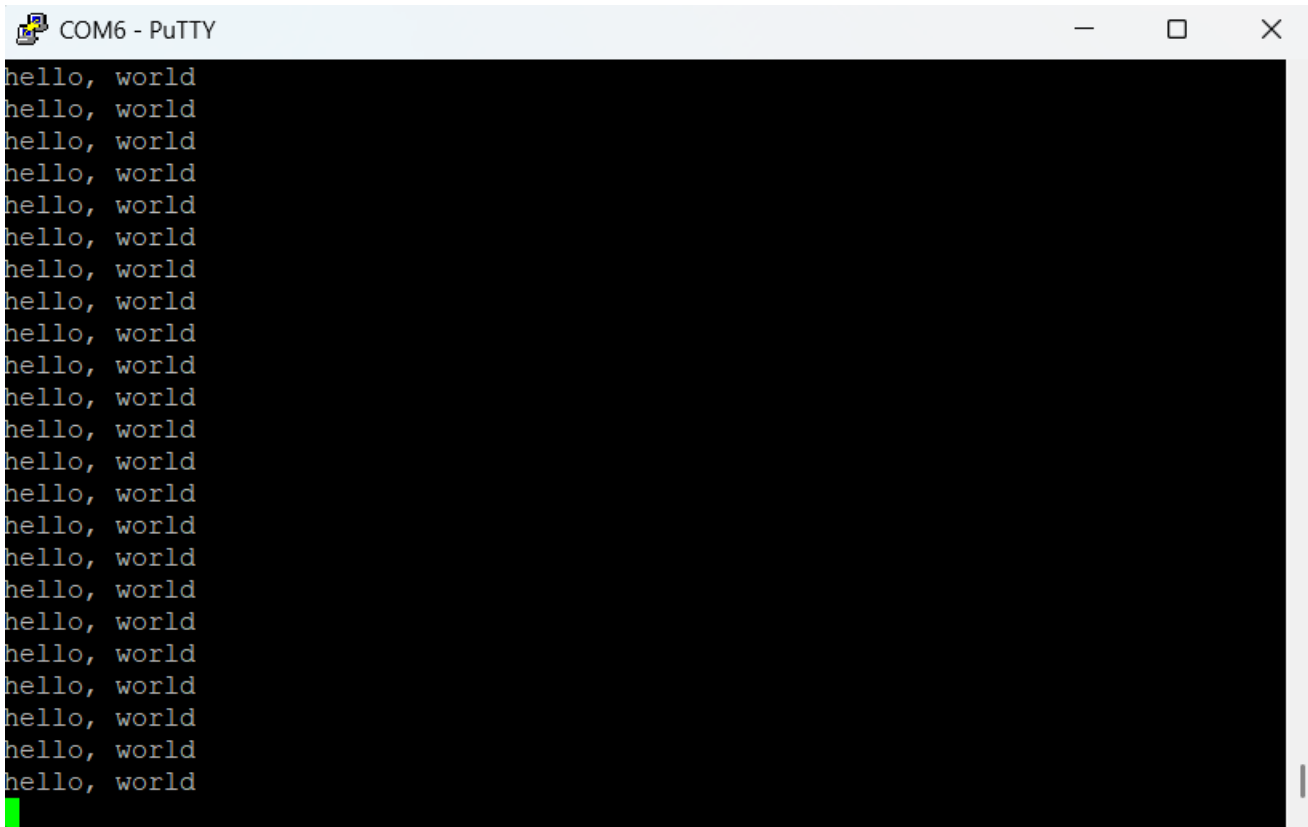

Run OpenOCD with the below config.

```
openocd -f interface/cmsis-dap.cfg -ftarget/rp2350.cfg -c "adapter speed 5000"
```

Open a new terminal and then run the following to launch our dynamic debugger called GDB.

```
arm-none-eabi-gdb build/0x0001_hello-world.elf
```

Once it loads, we need to target our remote server.

```
target remote :3333
```

We need to halt the currently running binary.

```
monitor reset halt
```

We notice our *hello, world* within the serial monitor is halted as expected.

Let's re-examine main.

```
(gdb) x/5i 0x10000234
0x10000234 <main>:  push    {r3, lr}
0x10000236 <main+2>:  bl      0x1000156c <stdio_init_all>
0x1000023a <main+6>:  ldr    r0, [pc, #8]    @ (0x10000244 <main+16>)
0x1000023c <main+8>:  bl      0x100015fc <__wrap_puts>
0x10000240 <main+12>: b.n     0x1000023a <main+6>
```

The first thing we need to do to hack our system LIVE is to set a breakpoint to the address right before the call to puts and then continue.

```
(gdb) b *0x1000023c
Breakpoint 1 at 0x1000023c: file C:/Users/assem.KEVINTHOMAS/Documents/Embedded-
Hacking/0x0001_hello-world/0x0001_hello-world.c, line 8.
Note: automatically using hardware breakpoints for read-only addresses.
(gdb) c
Continuing.
```

```
Thread 1 "rp2350.cm0" hit Breakpoint 1, 0x1000023c in main ()
   at C:/Users/assem.KEVINTHOMAS/Documents/Embedded-Hacking/0x0001_hello-world/0x0001_hello-
world.c:8
warning: Source file is more recent than executable.
8      printf("hello, world\r\n");
```

```
(gdb) disas
Dump of assembler code for function main:
   0x10000234 <+0>:  push    {r3, lr}
   0x10000236 <+2>:  bl      0x1000156c <stdio_init_all>
   0x1000023a <+6>:  ldr    r0, [pc, #8]    @ (0x10000244 <main+16>)
=>  0x1000023c <+8>:  bl      0x100015fc <__wrap_puts>
   0x10000240 <+12>: b.n     0x1000023a <main+6>
   0x10000242 <+14>:  nop
   0x10000244 <+16>:  adds   r4, r1, r7
   0x10000246 <+18>:  asrs   r0, r0, #32
End of assembler dump.
(gdb)
```

The next thing we need to do is hijack the value of *hello, world* which is pointed to in *r0* and create our own data and fill it with a hacked malicious string.

```
(gdb) x/s $r0
0x100019cc:  "hello, world\r"
(gdb) set $r0 = "hacky, world\r"
evaluation of this expression requires the program to have a function "malloc".
```

```
(gdb) x/s $r0
0x100019cc:  "hello, world\r"
```

Oh no it did not work! Now what!

GDB interprets "hacky, world\r" as a string literal, and it tries to evaluate it as a pointer to a valid memory address where that string resides. But GDB itself does not allocate memory for that string unless the program being debugged has already loaded it somewhere, typically via the C runtime or a statically defined string in the binary.

The error isn't because GDB is trying to call `malloc`. It's because GDB is trying to resolve the string literal to a memory address, and it fails because that string doesn't exist in the program's memory space. If you're debugging a bare-metal binary or early startup code on the RP2350, there's no runtime environment to provide that string, and no global symbols or `.data` section initialized with it.

Therefore, we need to create our string in SRAM!

If we remember from the last chapter, the RP2350 datasheet states that the SRAM starts at `0x20000000`. With that we can create a new string in SRAM directly.

```
(gdb) set {char[14]} 0x20000000 = {'h','a','c','k','y',' ',' ',' ','w','o','r','l','d','\r','\0'}
(gdb) x/s 0x20000000
0x20000000 <ram_vector_table>: "hacky, world\r"
```

Now to need to hijack the address inside `r0` and change it to our hacked address in SRAM and verify our hack.

```
(gdb) set $r0 = 0x20000000
(gdb) x/x $r0
0x20000000 <ram_vector_table>: 0x68
(gdb) x/s $r0
0x20000000 <ram_vector_table>: "hacky, world\r"
```

Let's continue and execute our hack!

```
(gdb) c
Continuing.
```

```
Thread 1 "rp2350.cm0" hit Breakpoint 1, 0x1000023c in main ()
    at C:/Users/assem.KEVINTHOMAS/Documents/Embedded-Hacking/0x0001_hello-world/0x0001_hello-
world.c:8
8             printf("hello, world\r\n");
```

Chapter 4: Embedded System Analysis

We are working with a microcontroller so there is no operating system in use. This is what we refer to as bare-metal programming.

We must start with what happens when the RP2350 gets power.

The RP2350 has an on-chip bootloader (bootrom) that executes immediately when the chip gets power.

```
// ROOT ADDRESSES
#define BOOTROM_MAGIC_OFFSET 0x10
#define BOOTROM_FUNC_TABLE_OFFSET 0x14
#if PICO_RP2040
#define BOOTROM_DATA_TABLE_OFFSET 0x16
#endif

#if PICO_RP2040
#define BOOTROM_VTABLE_OFFSET 0x00
#define BOOTROM_TABLE_LOOKUP_OFFSET 0x18
#else
#define BOOTROM_WELL_KNOWN_PTR_SIZE 2
#if defined(__riscv)
#define BOOTROM_ENTRY_OFFSET 0x7dfc
#define BOOTROM_TABLE_LOOKUP_ENTRY_OFFSET (BOOTROM_ENTRY_OFFSET -
BOOTROM_WELL_KNOWN_PTR_SIZE)
#define BOOTROM_TABLE_LOOKUP_OFFSET (BOOTROM_ENTRY_OFFSET -
BOOTROM_WELL_KNOWN_PTR_SIZE*2)
#else
#define BOOTROM_VTABLE_OFFSET 0x00

```

src/rp2_common/boot_bootrom_headers/include/boot/bootrom_constants.h

The RP2350 bootrom is a mask ROM that contains the first-stage bootloader code. This bootrom provides various functions including flash initialization, boot path selection, and hardware setup.

```
static inline void rom_connect_internal_flash(void) {
    rom_connect_internal_flash_fn func = (rom_connect_internal_flash_fn)
rom_func_lookup_inline(ROM_FUNC_CONNECT_INTERNAL_FLASH);
    func();
}
```

src/rp2_common/pico_bootrom/include/pico/bootrom.h

On RP2350, boot stage 2 is called as a regular function and must return normally, unlike RP2040, **boot2_generic_03h.S**. The second stage bootloaders are responsible for setting up external flash to enable XIP operation.

```

// The QMI is automatically configured for 03h XIP straight out of reset,
// but this code can't assume it's still in that state. Set up memory
// window 0 for 03h serial reads.

// Setup timing parameters: short sequential-access cooldown, configured
// CLKDIV and RXDELAY, and no constraints on CS max assertion, CS min
// deassertion, or page boundary burst breaks.

#define INIT_M0_TIMING (\
    1          << QMI_M0_TIMING_COOLDOWN_LSB |\
    PICO_FLASH_SPI_RXDELAY << QMI_M0_TIMING_RXDELAY_LSB |\
    PICO_FLASH_SPI_CLKDIV  << QMI_M0_TIMING_CLKDIV_LSB |\
0)

// Set command constants
#define INIT_M0_RCMD (\
    CMD_READ          << QMI_M0_RCMD_PREFIX_LSB |\
0)

// Set read format to all-serial with a command prefix
#define INIT_M0_RFMT (\
    QMI_M0_RFMT_PREFIX_WIDTH_VALUE_S << QMI_M0_RFMT_PREFIX_WIDTH_LSB |\
    QMI_M0_RFMT_ADDR_WIDTH_VALUE_S   << QMI_M0_RFMT_ADDR_WIDTH_LSB   |\
    QMI_M0_RFMT_SUFFIX_WIDTH_VALUE_S << QMI_M0_RFMT_SUFFIX_WIDTH_LSB  |\
    QMI_M0_RFMT_DUMMY_WIDTH_VALUE_S  << QMI_M0_RFMT_DUMMY_WIDTH_LSB   |\
    QMI_M0_RFMT_DATA_WIDTH_VALUE_S   << QMI_M0_RFMT_DATA_WIDTH_LSB   |\
    QMI_M0_RFMT_PREFIX_LEN_VALUE_8   << QMI_M0_RFMT_PREFIX_LEN_LSB   |\
0)

```

The default `boot2_generic_03h` implementation configures the QMI for basic serial flash operation.
`src/rp2350/boot_stage2/boot2_generic_03h.S`

The configuration sets up timing parameters with a short cooldown, configurable clock divider and RX delay, and configures the QMI for 03h serial read commands with all-serial format.

After QMI configuration, boot stage 2 performs a dummy transfer to initialize the flash device and then configures continuous read mode.

```

// Dummy transfer
mov r1, #XIP_NOCACHE_NOALLOC_BASE
ldrb r1, [r1]

// Set prefix length to 0, as flash no longer expects to see commands
bic r0, #QMI_M0_RFMT_PREFIX_LEN_BITS
str r0, [r3, #QMI_M0_RFMT_OFFSET]

```

`src/rp2350/boot_stage2/boot2_w25q080.S`

The dummy transfer activates XIP mode, and the prefix length is set to 0 since the flash no longer expects command prefixes for subsequent reads.

Boot stage 2 returns control to the bootrom, which then jumps to the `reset_vector` as that value is the second entry in the vector table at `0x10000004` which in our case is `0x1000015d`.

```
// Pull in standard exit routine
#include "boot2_helpers/exit_from_boot2.S"
```

We will focus on execute in place, or XIP, a technique where firmware instructions are executed directly from non-volatile memory rather than being copied into RAM. In the context of the RP2350, this typically means that code is mapped from external or internal Flash memory into the processor's address space, allowing instructions to be fetched and executed without relocation.

This approach conserves RAM and simplifies startup, since the processor can begin executing code immediately after reset. The Flash region is memory-mapped, so the CPU treats it as part of its normal instruction space. While XIP is efficient for read-only code execution, it's important to note that Flash access times are generally slower than RAM, and write operations require special handling.

Understanding XIP is essential for debugging and reverse engineering, as it affects how code is laid out, how breakpoints behave, and how memory regions are protected or cached. Let me know if you'd like to walk through the RP2350's memory map or trace instruction fetches from Flash during startup.

When we examine the first few values at 0x10000000, we begin with the vector table.

```
(gdb) x/4x 0x10000000
0x10000000 <__vectors>: 0x20082000      0x1000015d      0x1000011b      0x1000011d

Address      Value      Meaning
0x10000000  0x20082000 Initial Stack Pointer (SP)
0x10000004  0x1000015d Reset Handler (entry point after boot)
0x10000008  0x1000011b NMI Handler
0x1000000C  0x1000011d HardFault Handler
```

The reset handler is at 0x1000015d, so disassembling from there will show the actual startup logic.

```
(gdb) x/3i 0x1000015d
0x1000015d <_reset_handler>: mov.w    r0, #3489660928 @ 0xd0000000
0x10000161 <_reset_handler+4>: ldr    r0, [r0, #0]
0x10000163 <_reset_handler+6>: cbz   r0, 0x1000016a <hold_non_core0_in_bootrom+6>
```

On ARM Cortex-M chips, all code runs in Thumb mode, and the processor uses the least significant bit of an address to mark this: if bit 0 is set, it means "Thumb," if clear, it means "ARM." The actual instructions still live at even addresses, but debuggers and disassemblers handle this flag differently as GDB shows the address exactly as it appears in the vector table (with the Thumb bit set), while Ghidra strips that bit off and shows the true instruction address. So, both are correct, they're just presenting the same location in two slightly different ways.

Let's start from the reset handler and work our way to main.

At 0x1000015d: mov.w r0, #0xd0000000 - Load SIO base address.

At 0x10000161: ldr r0, [r0, #0x0] - Read the CPUID register.

At 0x10000163: cbz r0, LAB_1000016a - Branch if core 0 (r0 == 0).

```
*****
*
*                               FUNCTION
*****
undefined _reset_handler()
    assume LRset = 0x0
    assume TMode = 0x1
undefined  ▲ <UNASSIGNED> <RETURN>
    _reset_handler
    crt0.S:446 (4)
1000015c 4f f0 50 40    mov.w    r0,#0xd0000000
    crt0.S:447 (2)
10000160 00 68            ldr     r0,[r0,#0x0]=>DAT_d0000000
    crt0.S:452 (2)
10000162 10 b1            cbz    r0,LAB_1000016a
```

At 0x10000164-0x10000168, if not core 0, send back to bootrom.

```
    hold_non_core0_in_bootrom
    crt0.S:456 (4)
10000164 4f f0 00 00    mov.w    r0,#0x0
    crt0.S:457 (2)
10000168 f2 e7            b      _enter_vtable_in_r0
```

Data Copy Phase (0x1000016a-0x10000176)

- Copies initialized data from flash to RAM using the data_cpy_table.

- The loop at LAB_1000016c processes each entry in the copy table.

```

LAB_1000016a                                XREF[1]: 10000162(j)
crt0.S:481 (2)
1000016a 0d a4      adr      r4, [0x100001a0]

LAB_1000016c                                XREF[1]: 10000176(j)
crt0.S:485 (2)
1000016c 0e cc      ldmia   r4!, {r1,r2,r3}=>data_cpy_table
                                                    = 10003804h
                                                    = 20000110h
                                                    = 2000062Ch
                                                    = 10003D20h
                                                    = 20080000h
                                                    = D3h

crt0.S:486 (2)
1000016e 00 29      cmp     r1,
crt0.S:487 (2)
10000170 02 d0      beq     LAB byte 0h      0
crt0.S:488 (4)
10000172 00 f0 12 f8  bl     data_cpy          undefined data_cpy()
crt0.S:489 (2)
10000176 f9 e7      b      LAB_1000016c

```

BSS Clear Phase (0x10000178-0x10000184)

- Zeros out the BSS section in RAM.
- The loop clears memory from 0x2000062c to 0x20000858.

```
LAB_10000178                                XREF[1]: 10000170(j)
crt0.S:494 (2)
10000178 15 49      ldr      r1,[DAT_100001d0]                = 2000062Ch
crt0.S:495 (2)
1000017a 16 4a      ldr      r2,[DAT_100001d4]                = 20000858h
crt0.S:496 (2)
1000017c 00 20      movs     r0,#0x0
crt0.S:497 (2)
1000017e 00 e0      b        bss_fill_test

bss_fill_loop                               XREF[1]: 10000184(j)
crt0.S:499 (2)
10000180 01 c1      stmia    r1!,>__TMC_END__,{r0}

bss_fill_test                               XREF[1]: 1000017e(j)
crt0.S:501 (2)
10000182 91 42      cmp      r1,r2
crt0.S:502 (2)
10000184 fc d1      bne     bss_fill_loop
```

Runtime Initialization (0x10000186-0x10000188)

- Calls runtime_init.
- This sets up the C runtime environment.

```
platform_entry
crt0.S:512 (2)
10000186 14 49      ldr      r1,[DAT_100001d8]                = 10002E7Dh
crt0.S:513 (2)
10000188 88 47      blx     r1=>runtime_init                 void runtime_init(void)
```

Main Function Call (0x1000018a-0x1000018c)

- Finally calls main at 0x10000234.

```
crt0.S:514 (2)
1000018a 14 49      ldr      r1,[DAT_100001dc]                = 10000235h
crt0.S:515 (2)
1000018c 88 47      blx     r1=>main                          int main(void)
```

But where does this all come from?

We setup VSCode with the Pico extension. In Windows you will see something like the following.
C:\Users\assem.KEVINTHOMAS\.pico-sdk\sdk\2.2.0\src\rp2_common\pico crt0

There is a file called **crt0.S** to which this all begins!

Below is a snippet from the file.

```
.section .vectors, "ax"
.align 2

.global __vectors, __VECTOR_TABLE, __vectors_end
__VECTOR_TABLE:
__vectors:
.word __StackTop
.word _reset_handler
```

These entries correspond to `0x20082000` which is the stack pointer and `0x1000015d` which is the reset handler.

The RP2350 vector table is a critical structure that defines how the microcontroller responds to exceptions and interrupts, but it's not the first thing the ARM Cortex-M33 core looks at when it powers up as the on-chip bootrom executes first, followed by boot stage 2 configuration of the flash interface, and only then does the bootrom read the vector table and jump to the application's reset handler.

The vector table lives at `0x10000000` in the RP2350's XIP Flash region with the stack pointer at offset `0x00` and the reset vector at offset `0x04`, but this location is determined by the application's linker script rather than being a fixed hardware requirement as the bootrom uses the Vector Table Offset Register (VTOR) to locate the table dynamically.

We will find the linker scripts specifically for our 2.2.0 sdk in a folder similar to this.

C:\Users\assem.KEVINTHOMAS\.pico-sdk\sdk\2.2.0\src\rp2_common\pico crt0\rp2350

There you will see **memmap_default.ld** which is the standard XIP configuration where code executes directly from Flash at `0x10000000`.

In our linker script we see the following.

```
MEMORY
{
    INCLUDE "pico_flash_region.ld"
    RAM(rwx) : ORIGIN = 0x20000000, LENGTH = 512k
    SCRATCH_X(rwx) : ORIGIN = 0x20080000, LENGTH = 4k
    SCRATCH_Y(rwx) : ORIGIN = 0x20081000, LENGTH = 4k
}
```

Then as we look deeper, we see the following.

```
__StackTop = ORIGIN(SCRATCH_Y) + LENGTH(SCRATCH_Y);
```

We see above that the `ORIGIN(SCRATCH_Y)` is `0x20081000` and the length is 4k therefore we get the following

which we can verify in GDB.

```
__StackTop = 0x20081000 + 0x1000 = 0x20082000
```

```
(gdb) x/x 0x10000000
0x10000000 <__vectors>: 0x20082000
```

This value is emitted into the vector table at address 0x10000000 via the **crt0.S** file.

```
.section .vectors, "ax"
.align 2

.global __vectors, __VECTOR_TABLE, __vectors_end
__VECTOR_TABLE:
__vectors:
.word __StackTop
.word reset_handler
```

The Cortex-M33 core loads this into the stack pointer register and places the stack at the top of the `SCRATCH_Y` region, which is a small, dedicated RAM block reserved for the core 0 stack.

At the end of the vector table, we see the following.

```
(gdb) x/36i 0x10000110
0x10000110 <isr_usagefault>: mrs      r0, IPSR
0x10000114 <isr_usagefault+4>: subs   r0, #16
0x10000116 <unhandled_user_irq_num_in_r0>: bkpt   0x0000
0x10000118 <isr_invalid>: bkpt   0x0000
0x1000011a <isr_nmi>: bkpt   0x0000
0x1000011c <isr_hardfault>: bkpt   0x0000
0x1000011e <isr_svcall>: bkpt   0x0000
0x10000120 <isr_pendsv>: bkpt   0x0000
0x10000122 <isr_systick>: bkpt   0x0000
0x10000124 <__default_isrs_end>:                               @ <UNDEFINED> instruction: 0xebf27188
0x10000128 <__default_isrs_end+4>: subs   r0, r4, r4
0x1000012a <__default_isrs_end+6>: asrs   r0, r0, #32
0x1000012c <__default_isrs_end+8>: subs   r4, r1, r5
0x1000012e <__default_isrs_end+10>: asrs   r0, r0, #32
0x10000130 <__default_isrs_end+12>: lsls   r0, r4, #6
0x10000132 <__default_isrs_end+14>: asrs   r0, r0, #32
0x10000134 <__default_isrs_end+16>: add    r3, pc, #576      @ (adr r3, 0x10000378
<runtime_init_per_core_irq_priorities+44>)
0x10000136 <__default_isrs_end+18>: b.n    0xfffff6e
0x10000138 <__binary_info_header_end>: udf    #211          @ 0xd3
0x1000013a <__binary_info_header_end+2>:                               @ <UNDEFINED> instruction:
0xfffff0142
0x1000013e <__binary_info_header_end+6>: asrs   r1, r4, #32
0x10000140 <__binary_info_header_end+8>: lsls   r7, r7, #7
0x10000142 <__binary_info_header_end+10>: movs   r0, r0
0x10000144 <__binary_info_header_end+12>: subs   r0, r6, r6
0x10000146 <__binary_info_header_end+14>: movs   r0, r0
0x10000148 <__binary_info_header_end+16>: adds   r5, #121      @ 0x79
0x1000014a <__binary_info_header_end+18>: add    r3, sp, #72   @ 0x48
0x1000014c <entry_point>: mov.w  r0, #0
0x10000150 <enter_vtable_in_r0>: ldr    r1, [pc, #120] @ (0x100001cc
```

```

<data_cpy_table+44>
0x10000152 <_enter_vtable_in_r0+2>: str    r0, [r1, #0]
0x10000154 <_enter_vtable_in_r0+4>: ldmia  r0!, {r1, r2}
0x10000156 <_enter_vtable_in_r0+6>: msr    MSP, r1
0x1000015a <_enter_vtable_in_r0+10>: bx     r2
0x1000015c <_reset_handler>: mov.w  r0, #3489660928 @ 0xd0000000
0x10000160 <_reset_handler+4>: ldr    r0, [r0, #0]
0x10000162 <_reset_handler+6>: cbz    r0, 0x1000016a <hold_non_core0_in_bootrom+6>

```

The first section is the `isr_usagefault` to which we will do a little digging.

```

arm-none-eabi-nm -C build\0x0001_hello-world.elf | findstr isr_usagefault
10000110 W isr_usagefault

```

This means this is weakly defined as `__crt0.S` has only the stub but the code we see below is elsewhere.

```

0x10000110 <isr_usagefault>: mrs     r0, IPSR
0x10000114 <isr_usagefault+4>: subs   r0, #16

```

In `__crt0.S` we see the following.

```

// Declare a weak symbol for each ISR.
// By default, they will fall through to the undefined IRQ handler below (breakpoint),
// but can be overridden by C functions with correct name.

.macro decl_isr_bkpt name
.weak \name
.type \name,%function
.thumb_func
\name:
    bkpt #0
.endm

```

We can try searching with PowerShell.

```

PS C:\Users\assem.KEVINTHOMAS> Get-ChildItem -Recurse -Include *.S -Path
"C:\Users\assem.KEVINTHOMAS\pico-sdk" | Select-String "mrs r0, IPSR"

```

Sadly, this returns no result. Let's look within our running GDB instance.

```

(gdb) list isr_usagefault
315     .global __unhandled_user_irq
316     .thumb_func
317     __unhandled_user_irq:
318     // if we include the implementation if there could be a valid IRQ hanler in the
vtable that uses it
319     #if !(PICO_NO_RAM_VECTOR_TABLE && PICO_MINIMAL_STORED_VECTOR_TABLE)
320         mrs r0, ipsr
321         subs r0, #16
322     .global unhandled_user_irq_num_in_r0
323     unhandled_user_irq_num_in_r0:
324     #endif

```

Now when we look in `__crt0.S`, we can see the following.

```

// All unhandled USER IRQs fall through to here.
// Additionally, if the Armv9-M MemManage/BusFault/UsageFault/SecureFault/DebugMonitor
exceptions
// are enabled, but the handlers are not defined, then unhandled_user_irq_num_in_r0 will
// also be reached, but with a negative exception number (e.g. MemManage == -12)
.global __unhandled_user_irq
.thumb_func
__unhandled_user_irq:
// if we include the implementation if there could be a valid IRQ hanler in the vtable
that uses it
#if !(PICO_NO_RAM_VECTOR_TABLE && PICO_MINIMAL_STORED_VECTOR_TABLE)
    mrs r0, ipsr
    subs r0, #16
#endif

```

Let's now examine the next few lines of GDB.

```

(gdb) x/36i 0x10000110
..
0x10000116 <unhandled_user_irq_num_in_r0>: bkpt 0x0000
0x10000118 <isr_invalid>: bkpt 0x0000
0x1000011a <isr_nmi>: bkpt 0x0000
0x1000011c <isr_hardfault>: bkpt 0x0000
0x1000011e <isr_svcall>: bkpt 0x0000
0x10000120 <isr_pendsv>: bkpt 0x0000
0x10000122 <isr_systick>: bkpt 0x0000
..

```

We can see in **crt0.S**, directly below our other code, we see the following.

```
.global unhandled_user_irq_num_in_r0
unhandled_user_irq_num_in_r0:
#endif
    // note the next instruction is a breakpoint too, however we have a 2 byte alignment
hole
    // and it is preferable to have distinct labels, to inform the user what has happened
in the debugger.
    bkpt #0

decl_isr_bkpt isr_invalid
#if !PICO_MINIMAL_STORED_VECTOR_TABLE
// these are separated out into individual BKPT instructions with label for clarity
decl_isr_bkpt isr_nmi
decl_isr_bkpt isr_hardfault
decl_isr_bkpt isr_svcall
decl_isr_bkpt isr_pendsv
decl_isr_bkpt isr_systick
#endif
```

Let's continue our analysis with the next few lines.

```
(gdb) x/36i 0x10000110
..
0x10000124 <__default_isr_end>: @ <UNDEFINED> instruction: 0xebf27188
0x10000128 <__default_isr_end+4>: subs    r0, r4, r4
0x1000012a <__default_isr_end+6>: asrs    r0, r0, #32
0x1000012c <__default_isr_end+8>: subs    r4, r1, r5
0x1000012e <__default_isr_end+10>: asrs    r0, r0, #32
0x10000130 <__default_isr_end+12>: lsls    r0, r4, #6
0x10000132 <__default_isr_end+14>: asrs    r0, r0, #32
0x10000134 <__default_isr_end+16>: add     r3, pc, #576 @ (adr r3, 0x10000378
<runtime_init_per_core_irq_priorities+44>)
0x10000136 <__default_isr_end+18>: b.n     0xfffff6e
..
```

In our **crt0.S**, we see only the following.

```
.global __default_isr_end
__default_isr_end:
```

Where does this actual code come from?

It's not code it is a binary-info header emitted by the startup assembly, sitting immediately after the default ISR marker.

In PowerShell, let's do the following.

```
arm-none-eabi-objdump -d --source build\0x0001_hello-world.elf |
  Select-String '^\\s*1000012[4-9]|^\\s*1000013[0-6]' -Context 1,2 |
  ForEach-Object { $_.Context.PreContext + $_.Line + $_.Context.PostContext } |
  ForEach-Object { $_.Trim() } |
  Where-Object { $_ -ne "" } |
  Select-Object -Unique
10000124 <__default_isrs_end>:
10000124:      7188ebf2      .word    0x7188ebf2
10000128:     10001b20      .word    0x10001b20
1000012c:     10001b4c      .word    0x10001b4c
10000130:     100001a0      .word    0x100001a0
10000134:     e71aa390      .word    0xe71aa390
10000138 <__binary_info_header_end>:
```

Address	Value	Field / Symbol	Description
0x10000124	0x7188EBF2	Magic signature	A fixed identifier marking the start of the binary-info header. Used by tools/boot ROM to recognize this structure.
0x10000128	0x10001B20	Binary info start pointer	Address of the first entry in the .binary_info section. In this build, that's __bi_ptr84.
0x1000012C	0x10001B4C	Binary info end pointer	Address just past the last .binary_info entry. Here it's start + 0x2C bytes.
0x10000130	0x100001A0	Data copy table pointer	Address of data_cpy_table, used by the reset handler to copy initialised .data from flash to RAM.
0x10000134	0xE71AA390	Reserved / trailer constant	A fixed value defined in the SDK's startup assembly; may serve as a checksum, version marker, or reserved field.
0x10000138	(label)	__binary_info_header_end	Symbol marking the end of the binary-info header block.

```
PS C:\Users\assem.KEVINTHOMAS\Documents\Embedded-Hacking\0x0001_hello-world> arm-none-eabi-objdump -s -j .text build\0x0001_hello-world.elf | Select-String "10000120" -Context 0,6
```

```
10000120 00be00be f2eb8871 201b0010 4c1b0010 .....q ...L...
10000130 a0010010 90a31ae7 d3deffff 42012110 .....B.!.
10000140 ff010000 b01b0000 793512ab 4ff00000 .....y5..O...
10000150 1e490860 06c881f3 08881047 4ff05040 .I.`.....GO.P@
10000160 006810b1 4ff00000 f2e70da4 0ecc0029 .h..O.....)
10000170 02d000f0 12f8f9e7 1549164a 002000e0 .....I.J. ..
10000180 01c19142 fcd11449 88471449 88471449 ...B...I.G.I.G.I
```

Let's continue with our GDB analysis.

```
(gdb) x/36i 0x10000110
..
0x10000138 <__binary_info_header_end>:      udf      #211    @ 0xd3
0x1000013a <__binary_info_header_end+2>:      @ <UNDEFINED> instruction:
0xffff0142
0x1000013e <__binary_info_header_end+6>:      asrs     r1, r4, #32
0x10000140 <__binary_info_header_end+8>:      lsls     r7, r7, #7
0x10000142 <__binary_info_header_end+10>:     movs     r0, r0
0x10000144 <__binary_info_header_end+12>:     subs     r0, r6, r6
0x10000146 <__binary_info_header_end+14>:     movs     r0, r0
0x10000148 <__binary_info_header_end+16>:     adds     r5, #121      @ 0x79
0x1000014a <__binary_info_header_end+18>:     add      r3, sp, #72      @ 0x48
..
```

In **crt0.S** we see the following.

```
.section .binary_info_header, "a"

// Header must be in first 256 bytes of main image (i.e. excluding flash boot2).
// For flash builds we put it immediately after vector table; for NO_FLASH the
// vectors are at a +0x100 offset because the bootrom enters RAM images directly
// at their lowest address, so we put the header in the VTOR alignment hole.

#if !PICO_NO_BINARY_INFO
binary_info_header:
.word BINARY_INFO_MARKER_START
.word __binary_info_start
.word __binary_info_end
.word data_cpy_table // we may need to decode pointers that are in RAM at runtime.
.word BINARY_INFO_MARKER_END
#endif

#include "embedded_start_block.inc.S"
```

Let's dig in and see what we can find.

```
arm-none-eabi-objdump -d --source build\0x0001_hello-world.elf |
  Select-String '^\\s*1000013[8-9]|^\\s*1000014[0-9a-f]' -Context 1,2 |
  ForEach-Object { $_.Context.PreContext + $_.Line + $_.Context.PostContext } |
  ForEach-Object { $_.Trim() } |
  Where-Object { $_ -ne "" } |
  Select-Object -Unique
10000138 <__binary_info_header_end>:
10000138:      fffffded3      .word    0xffffded3
1000013c:      10210142      .word    0x10210142
10000140:      000001ff      .word    0x000001ff
10000144:      00001bb0      .word    0x00001bb0
10000148:      ab123579      .word    0xab123579
```

```
PS C:\Users\assem.KEVINTHOMAS\Documents\Embedded-Hacking\0x0001_hello-world> arm-none-eabi-objdump -s --start-address=0x10000138 --stop-address=0x1000014c build\0x0001_hello-world.elf
```

```
build\0x0001_hello-world.elf:      file format elf32-littlearm
```

```
Contents of section .text:
```

```
 10000138 d3deffff 42012110 ff010000 b01b0000  ....B.!.....
 10000148 793512ab                y5..
```

```
PS C:\Users\assem.KEVINTHOMAS\Documents\Embedded-Hacking\0x0001_hello-world> # Dump all symbols and grep for our addresses
```

```
PS C:\Users\assem.KEVINTHOMAS\Documents\Embedded-Hacking\0x0001_hello-world> arm-none-eabi-nm --numeric-sort build\0x0001_hello-world.elf |
```

```
>>      Select-String "10000138|1000013c|10000140|10000144|10000148"
```

```
10000138 T __binary_info_header_end
```

```
10000138 t embedded_block
```

```
Raw words and interpretations.
```

```
0x10000138: 0xFFFFDED3
```

- Marker start: Picobin block start marker (BlockMarkerStart).

```
0x1000013C: 0x10212142
```

- Four item-header bytes: This is not a pointer; it's the first item header packed into 4 bytes (1B head/type + 1B size + 2B typedata). In default RP2350 builds this is the IMAGE_TYPE item emitted by embedded_start_block.inc.S3.

```
0x10000140: 0x000001FF
```

- Next item header bytes or size field: Another 4 bytes belonging to the item sequence (depends on which items are compiled in; see decode steps below). For minimum metadata images, you'll see the LAST item header here1.

```
0x10000144: 0x00001BB0
```

- Link to next block (relative bytes) or continuation of item data: Picobin blocks store a 32-bit link
- "offset to next block from this header." If END_BLOCK is enabled in your build, this will be a positive offset to the end block; otherwise, it is 0 to loop to self2.

```
0x10000148: 0xAB123579
```

- Marker end: Picobin block end marker (BlockMarkerEnd).

As we continue our analysis.

```
(gdb) x/36i 0x10000110
```

```
..
0x1000014c <_entry_point>:  mov.w   r0, #0
..
```

In **crt0.S** we see the following.

```
#if !PICO_CRT0_NO_RESET_SECTION
.section .reset, "ax"

// On flash builds, the vector table comes first in the image (conventional).
// On NO_FLASH builds, the reset handler section comes first, as the entry
// point is at offset 0 (fixed due to bootrom), and VTOR is highly-aligned.
// Image is entered in various ways:
//
// - NO_FLASH builds are entered from beginning by UF2 bootloader
//
// - Flash builds vector through the table into _reset_handler from boot2
//
// - Either type can be entered via _entry_point by the debugger, and flash builds
//   must then be sent back round the boot sequence to properly initialise flash

// ELF entry point:
.type _entry_point,%function
.thumb_func
.global _entry_point
_entry_point:
```

```

#if PICO_NO_FLASH
    // on the NO_FLASH case, we do not do a rest thru bootrom below, so the RCP may or may
not have been initialized:
    //
    // in the normal (e.g. UF2 download etc. case) we will have passed thru bootrom
initialization, but if
    // a NO_FLASH binary is loaded by the debugger, and run directly after a reset, then
we won't have.
    //
    // we must therefore initialize the RCP if it hasn't already been

#if HAS_REDUNDANCY_COPROCESSOR
    // just enable the RCP which is fine if it already was (we assume no other co-
processors are enabled at this point to save space)
    ldr r0, = PPB_BASE + M33_CPACR_OFFSET
    movs r1, #ARM_CPU_PREFIXED(CPACR_CP7_BITS)
    str r1, [r0]
    // only initialize canary seeds if they haven't been (as to do so twice is a fault)
    mrc p7, #1, apsr_nzcv, c0, c0, #0
    bmi 1f
    // i dont think it much matters what we initialized to, as to have gotten here we must
have not
    // gone thru the bootrom (which a secure boot would have)
    mcrr p7, #8, r0, r0, c0
    mcrr p7, #8, r0, r0, c1
    sev
1:
#endif
#if !__ARM_ARCH_6M__
    // Make sure stack limit is 0 if we came in thru the debugger; we do not know what it
should be
    movs r0, #0
    msr msplim, r0
#endif

    ldr r0, =__vectors
    // Vector through our own table (SP, VTOR will not have been set up at
// this point). Same path for debugger entry and bootloader entry.
#else
    // Debugger tried to run code after loading, so SSI is in 03h-only mode.
    // Go back through bootrom + boot2 to properly initialise flash.
    ldr r0, =BOOTROM_VTABLE_OFFSET
#endif

```

What we see is `ldr r0, =BOOTROM_VTABLE_OFFSET` and this optimizes down to `mov.w r0, #0`.

The rest of the code up to `main` is here and directly translates in **crt0.S** nicely. Let's break this down piece by piece.

```
_enter_vtable_in_r0:
    ldr r1, =(PPB_BASE + ARM_CPU_PREFIXED(VTOR_OFFSET))
    str r0, [r1]
    ldmia r0!, {r1, r2}
    msr msp, r1
    bx r2
```

(gdb) x/36i 0x10000110

```
..
0x10000150 <_enter_vtable_in_r0>:    ldr    r1, [pc, #120] @ (0x100001cc
<data_cpy_table+44>)
0x10000152 <_enter_vtable_in_r0+2>:  str    r0, [r1, #0]
0x10000154 <_enter_vtable_in_r0+4>:  ldmia  r0!, {r1, r2}
0x10000156 <_enter_vtable_in_r0+6>:  msr    MSP, r1
0x1000015a <_enter_vtable_in_r0+10>: bx     r2
..
```

On the RP2350's Cortex-M33 core, `_enter_vtable_in_r0` is a tiny hand-off routine that takes a pointer to a new vector table in `r0`, writes it into the Vector Table Offset Register (VTOR) so all future exceptions and interrupts use it, then reads the first two words from that table so the initial Main Stack Pointer value and the `Reset_Handler` address and loads the MSP accordingly, and finally branches to the `Reset_Handler`, effectively transferring execution as if the CPU had just reset into the new firmware.

```
.type _reset_handler,%function
.thumb_func
_reset_handler:
    // Note if we entered thru here on core 0, then we should have gone thru bootrom, so
    // SP (and MSPLIM) on Armv8-M
    // should already be set

    // Only core 0 should run the C runtime startup code; core 1 is normally
    // sleeping in the bootrom at this point but check to be sure (e.g. if
    // debugger put core 1 at the ELF entry point for some reason)
    ldr r0, =(SIO_BASE + SIO_CPUID_OFFSET)
    ldr r0, [r0]
#ifdef __ARM_ARCH_6M__
    cmp r0, #0
    beq 1f
#else
    cbz r0, 1f
#endif
```

(gdb) x/36i 0x10000110

```
..
0x1000015c <_reset_handler>: mov.w  r0, #3489660928 @ 0xd0000000
0x10000160 <_reset_handler+4>: ldr    r0, [r0, #0]
0x10000162 <_reset_handler+6>: cbz    r0, 0x1000016a
..
```

This `_reset_handler` snippet is the very first C-runtime entry point after reset on the RP2350, and its opening instructions are checking which CPU core is running. The `mov.w r0, #0xd0000000 / ldr r0, [r0]` sequence reads the `SIO_CPUID` register in the RP2350's SIO block, which returns 0 for core 0 and 1 for core 1. The `cbz r0, 1f` means "if this is core 0, branch to label 1," allowing only core 0 to proceed into the full C runtime startup (stack already set by the boot ROM). Core 1 normally sits idle in the boot ROM until explicitly started, so this guard prevents both cores from running the same initialization code and avoiding double-init of data sections, clocks, and peripherals if, for example, a debugger dropped core 1 directly at the ELF entry point.

```

hold_non_core0_in_bootrom:
    // Send back to the ROM to wait for core 0 to launch it.
    ldr r0, =BOOTROM_VTABLE_OFFSET
    b _enter_vtable_in_r0
1:

#if !PICO_RP2040 && PICO_EMBED_XIP_SETUP && !PICO_NO_FLASH
    // Execute boot2 on the core 0 stack (it also gets copied into BOOTRAM due
    // to inclusion in the data copy table below). Note the reference
    // to __boot2_entry_point here is what prevents the .boot2 section from
    // being garbage-collected.
    _copy_xip_setup:
        ldr r1, =__boot2_entry_point
        mov r3, sp
        add sp, #-256
        mov r2, sp
        bl data_cpy
    _call_xip_setup:
        mov r0, sp
        adds r0, #1
        blx r0
        add sp, #256
#endif

    // In a NO_FLASH binary, don't perform .data etc copy, since it's loaded
    // in-place by the SRAM load. Still need to clear .bss
#if !PICO_NO_FLASH
    adr r4, data_cpy_table

    // assume there is at least one entry
1:
    ldmia r4!, {r1-r3}
    cmp r1, #0
    beq 2f
    bl data_cpy
    b 1b
2:
#endif

```

```

(gdb) x/36i 0x10000110
..
0x10000164 <hold_non_core0_in_bootrom>:   mov.w   r0, #0
0x10000168 <hold_non_core0_in_bootrom+4>:   b.n     0x10000150 <_enter_vtable_in_r0>
0x1000016a <hold_non_core0_in_bootrom+6>:   add     r4, pc, #52      @ (adr r4, 0x100001a0)
<data_cpy_table>
0x1000016c <hold_non_core0_in_bootrom+8>:   ldmia  r4!, {r1, r2, r3}
0x1000016e <hold_non_core0_in_bootrom+10>:  cmp     r1, #0
0x10000170 <hold_non_core0_in_bootrom+12>:  beq.n  0x10000178
<hold_non_core0_in_bootrom+20>
0x10000172 <hold_non_core0_in_bootrom+14>:  bl      0x1000019a <data_cpy>
0x10000176 <hold_non_core0_in_bootrom+18>:  b.n     0x1000016c
<hold_non_core0_in_bootrom+8>
0x10000178 <hold_non_core0_in_bootrom+20>:  ldr     r1, [pc, #84]    @ (0x100001d0)
<data_cpy_table+48>
0x1000017a <hold_non_core0_in_bootrom+22>:  ldr     r2, [pc, #88]    @ (0x100001d4)
<data_cpy_table+52>
0x1000017c <hold_non_core0_in_bootrom+24>:  movs   r0, #0
0x1000017e <hold_non_core0_in_bootrom+26>:  b.n     0x10000182 <bss_fill_test>
..

```

This block funnels non-core0 straight back into the Boot ROM and then performs core0's C-runtime staging: the label loads `r0` with `BOOTROM_VTABLE_OFFSET` (in the build you're disassembling it assembles to 0) and immediately branches to `_enter_vtable_in_r0`, which installs the Boot ROM's vector table and jumps into its reset handler so secondary cores wait there until launched by core0; if we're on core0, the code optionally stages and runs the boot2 XIP setup stub on core0's stack (copy via `data_cpy`, then `blx` into it) to bring external flash online, then iterates the `data_cpy_table` with `ldmia r4!, {r1-r3}` until a zero sentinel in `r1`, copying each region described by the triples, and finally loads the `.bss` start/end from the literal pool, sets `r0=0`, and falls through to the `bss` zeroing routine.

```

// Zero out the BSS
ldr r1, =__bss_start__
ldr r2, =__bss_end__
movs r0, #0
b bss_fill_test
bss_fill_loop:
stm r1!, {r0}
bss_fill_test:
cmp r1, r2
bne bss_fill_loop

```

```

(gdb) x/36i 0x10000110
..
0x10000180 <bss_fill_loop>:  stmia  r1!, {r0}
0x10000182 <bss_fill_test>:  cmp     r1, r2
0x10000184 <bss_fill_test+2>:  bne.n  0x10000180 <bss_fill_loop>
..

```

This is the RP2350's standard `.bss` zero-fill loop that runs during C runtime startup to ensure all uninitialized global/static variables start at zero, as required by the C standard. It loads `__bss_start__` into `r1` and `__bss_end__` into `r2`, sets `r0` to zero, then repeatedly executes `stmia r1!, {r0}` to store that zero word into memory and post-increment `r1` to the next word. After each store, it compares `r1` to `r2`; if they're not equal, it branches back to `bss_fill_loop` and continues until the entire `.bss` region is cleared. Once `r1` reaches

__bss_end__, the loop exits and the system can safely enter main with all zero-initialized data in place.

```
platform_entry: // symbol for stack traces
#if PICO_CRT0_NEAR_CALLS && !PICO_COPY_TO_RAM
    bl runtime_init
```

(gdb) x/36i 0x10000110

```
..
0x10000186 <platform_entry>: ldr    r1, [pc, #80]    @ (0x100001d8 <data_cpy_table+56>)
0x10000188 <platform_entry+2>: blx   r1
0x1000018a <platform_entry+4>: ldr    r1, [pc, #80]    @ (0x100001dc
<data_cpy_table+60>)
0x1000018c <platform_entry+6>: blx   r1
0x1000018e <platform_entry+8>: ldr    r1, [pc, #80]    @ (0x100001e0
<data_cpy_table+64>)
0x10000190 <platform_entry+10>: blx   r1
0x10000192 <platform_entry+12>: bkpt  0x0000
0x10000194 <platform_entry+14>: b.n   0x10000192 <platform_entry+12>
0x10000196 <data_cpy_loop>: ldmia  r1!, {r0}
0x10000198 <data_cpy_loop+2>: stmia r2!, {r0}
0x1000019a <data_cpy>:      cmp    r2, r3
0x1000019c <data_cpy+2>:    bcc.n 0x10000196 <data_cpy_loop>
0x1000019e <data_cpy+4>:    bx     lr
0x100001a0 <data_cpy_table>: subs  r4, r1, r5
0x100001a2 <data_cpy_table+2>: asrs  r0, r0, #32
0x100001a4 <data_cpy_table+4>: lsls  r0, r2, #4
0x100001a6 <data_cpy_table+6>: movs  r0, #0
0x100001a8 <data_cpy_table+8>: lsls  r4, r5, #10
0x100001aa <data_cpy_table+10>: movs  r0, #0
0x100001ac <data_cpy_table+12>: adds  r0, r5, #3
0x100001ae <data_cpy_table+14>: asrs  r0, r0, #32
0x100001b0 <data_cpy_table+16>: movs  r0, r0
0x100001b2 <data_cpy_table+18>: movs  r0, #8
--Type <RET> for more, q to quit, c to continue without paging--
0x100001b4 <data_cpy_table+20>: movs  r0, r0
0x100001b6 <data_cpy_table+22>: movs  r0, #8
0x100001b8 <data_cpy_table+24>: adds  r0, r5, #3
0x100001ba <data_cpy_table+26>: asrs  r0, r0, #32
0x100001bc <data_cpy_table+28>: asrs  r0, r0, #32
0x100001be <data_cpy_table+30>: movs  r0, #8
0x100001c0 <data_cpy_table+32>: asrs  r0, r0, #32
0x100001c2 <data_cpy_table+34>: movs  r0, #8
0x100001c4 <data_cpy_table+36>: movs  r0, r0
0x100001c6 <data_cpy_table+38>: movs  r0, r0
0x100001c8 <data_cpy_table+40>: bx     lr
0x100001ca <data_cpy_table+42>: movs  r0, r0
0x100001cc <data_cpy_table+44>:      @ <UNDEFINED> instruction:
0xed08e000
0x100001d0 <data_cpy_table+48>: lsls  r4, r5, #10
0x100001d2 <data_cpy_table+50>: movs  r0, #0
0x100001d4 <data_cpy_table+52>: lsls  r0, r3, #19
0x100001d6 <data_cpy_table+54>: movs  r0, #0
0x100001d8 <data_cpy_table+56>: asrs  r5, r7, #13
0x100001da <data_cpy_table+58>: asrs  r0, r0, #32
0x100001dc <data_cpy_table+60>: lsls  r5, r6, #8
0x100001de <data_cpy_table+62>: asrs  r0, r0, #32
```

```

0x100001e0 <data_cpy_table+64>:      asrs    r5, r6, #13
0x100001e2 <data_cpy_table+66>:      asrs    r0, r0, #32
0x100001e4 <_init>: push    {r3, r4, r5, r6, r7, lr}
0x100001e6 <_init+2>:      nop
0x100001e8 <register_tm_clones>:      ldr     r3, [pc, #24]    @ (0x10000204
<register_tm_clones+28>)
0x100001ea <register_tm_clones+2>:      ldr     r1, [pc, #28]    @ (0x10000208
<register_tm_clones+32>)
0x100001ec <register_tm_clones+4>:      subs    r1, r1, r3
0x100001ee <register_tm_clones+6>:      asrs    r1, r1, #2
0x100001f0 <register_tm_clones+8>:      it      mi
0x100001f2 <register_tm_clones+10>:     addmi   r1, #1
0x100001f4 <register_tm_clones+12>:     asrs    r1, r1, #1
0x100001f6 <register_tm_clones+14>:     beq.n   0x10000200 <register_tm_clones+24>
0x100001f8 <register_tm_clones+16>:     ldr     r3, [pc, #16]    @ (0x1000020c
<register_tm_clones+36>)
0x100001fa <register_tm_clones+18>:     cbz     r3, 0x10000200 <register_tm_clones+24>
0x100001fc <register_tm_clones+20>:     ldr     r0, [pc, #4]     @ (0x10000204
<register_tm_clones+28>)
0x100001fe <register_tm_clones+22>:     bx      r3
--Type <RET> for more, q to quit, c to continue without paging--
0x10000200 <register_tm_clones+24>:     bx      lr
0x10000202 <register_tm_clones+26>:     nop
0x10000204 <register_tm_clones+28>:     lsls   r4, r5, #10
0x10000206 <register_tm_clones+30>:     movs   r0, #0
0x10000208 <register_tm_clones+32>:     lsls   r4, r5, #10
0x1000020a <register_tm_clones+34>:     movs   r0, #0
0x1000020c <register_tm_clones+36>:     movs   r0, r0
0x1000020e <register_tm_clones+38>:     movs   r0, r0
0x10000210 <frame_dummy>:      push   {r3, lr}
0x10000212 <frame_dummy+2>:      ldr     r3, [pc, #20]    @ (0x10000228 <frame_dummy+24>)
0x10000214 <frame_dummy+4>:      cbz     r3, 0x1000021e <frame_dummy+14>
0x10000216 <frame_dummy+6>:      ldr     r1, [pc, #20]    @ (0x1000022c <frame_dummy+28>)
0x10000218 <frame_dummy+8>:      ldr     r0, [pc, #20]    @ (0x10000230 <frame_dummy+32>)
0x1000021a <frame_dummy+10>:     nop.w
0x1000021e <frame_dummy+14>:     ldmia.w sp!, {r3, lr}
0x10000222 <frame_dummy+18>:     b.w    0x100001e8 <register_tm_clones>
0x10000226 <frame_dummy+22>:     nop
0x10000228 <frame_dummy+24>:     movs   r0, r0
0x1000022a <frame_dummy+26>:     movs   r0, r0
0x1000022c <frame_dummy+28>:     lsls   r0, r2, #18
0x1000022e <frame_dummy+30>:     movs   r0, #0
0x10000230 <frame_dummy+32>:     adds   r4, r1, r7
0x10000232 <frame_dummy+34>:     asrs   r0, r0, #32
..

```

In the final linked binary, `platform_entry` has been expanded far beyond the single `b1 runtime_init` you see in `crt0.S` as the compiler and linker have transformed that into a small call sequence that loads three function pointers from a nearby literal pool and calls them in turn. Those pointers, stored at `data_cpy_table+56`, `+60`, and `+64`, are filled in at link time with whatever initialization routines the Pico SDK and GCC's C runtime require. In a typical build, they correspond to the SDK's `runtime_init`, the standard `__libc_init_array` for running C++ constructors, and finally your application's `main` (or a wrapper). Using `ldr/blx` through a literal pool instead of a direct `b1` allows the linker to insert any combination of functions, handle long call distances, and keep the assembly source minimal.

Immediately after `platform_entry` is the `data_cpy` routine, a generic word-copy loop used earlier in startup to populate RAM sections from flash or other sources. It works by loading a word from the source pointer in `r1`, storing it to the destination in `r2`, and looping until `r2` reaches the end address in `r3`. The label `data_cpy_table` that follows is not actually executable code, it's a block of constants the startup code uses. The first part holds triples of (source, destination, end) addresses for each region that needs copying. Later entries include other constants such as the VTOR register address (`0xE000ED08` in little-endian form) and the `.bss` bounds, as well as the three function pointers used by `platform_entry`. GDB's disassembler shows these raw words as nonsensical Thumb instructions because it doesn't know they're data.

After this data region come a few standard GCC/EABI stubs: `_init`, `register_tm_clones`, and `frame_dummy`. These are pulled in automatically by the toolchain. `_init` is a hook for pre-main setup, often empty in embedded builds. The `register_tm_clones` and `frame_dummy`, are part of GCC's support for transactional memory and exception frame registration; on bare-metal targets they usually do nothing but are still linked in. Together, this sequence shows how a minimal assembly entry point in `crt0.S` grows into a fully linked startup chain, with the linker and runtime glue inserting the necessary initialization calls, memory setup routines, and housekeeping code before your program ever reaches `main`.

Chapter 5: Intro To Variables

In this chapter we are going to introduce the concept of a variable. If we have a series of boxes all laid out in a row and we numbered them from 0 to 9 (we start with 0 in Engineering) and then placed item 0 in box 0 and then item 1 in box 1 all the way to item 9 in box 9.

The boxes in this analogy represents our SRAM. The items are nothing more than variables of different types, which we will discuss later, that are stored in each of these addresses.

For the Developer, you simply provide a type and a name and the compiler will assign to the value to an actual address.

One of the most important considerations is that you have to declare variables before you use them in a program.

The process of declaration provides the compiler the size and name of the variable you are creating.

The process of definition allocates memory to a variable. These two processes are usually done at the same time.

Let's look at some code.

```
uint8_t age;
```

Here we have a data type which is `uint8_t` and the name of the variable which is `age`.

The data type determines how much space a variable is going to occupy in memory. This will signal the compiler to allocate space for it.

A semicolon signals to the compiler that a statement is complete. In our case the statement was the `uint8_t age`.

The `uint8_t` type takes up 1 byte of memory it is an unsigned integer type that can store a value between 0 and 255.

If you declare a value during declaration it is referred to as initialization.

Let's open up our folder **0x0005_intro-to-variables**.

Now let's review our **0x0005_intro-to-variables.c** file as this is located in the main folder.

```
#include <stdio.h>
#include "pico/stdlib.h"

int main(void) {
    uint8_t age = 42;

    age = 43;

    stdio_init_all();

    while (true)
        printf("age: %d\r\n", age);
}
```

Let's flash the uf2 file onto the Pico 2. If you are unsure about this step, please take a look at Chapter 1 to get re-familiar with this process.

The first lines you should be familiar with and if not again refer to Chapter 1 to get re-familiar with those lines.

Let's break down this code.

```
uint8_t age = 42;
```

We start by declaring and initializing the variable to hold a 1-byte unsigned integer and assign the value of 42 to it.

```
age = 43;
```

We then change the value stored in `age` to 43.

Then inside the while loop we have a `printf` where we print text to indicate that we are going to print the age and then use what we refer to as a format specifier which is `%d` to indicate we are using a decimal value and then our new line chars `\r\n` and then we have the value that will populate `%d` which is 43.

Let's open up PuTTY or your terminal editor of choice and we will see our values being printed in an infinite loop.

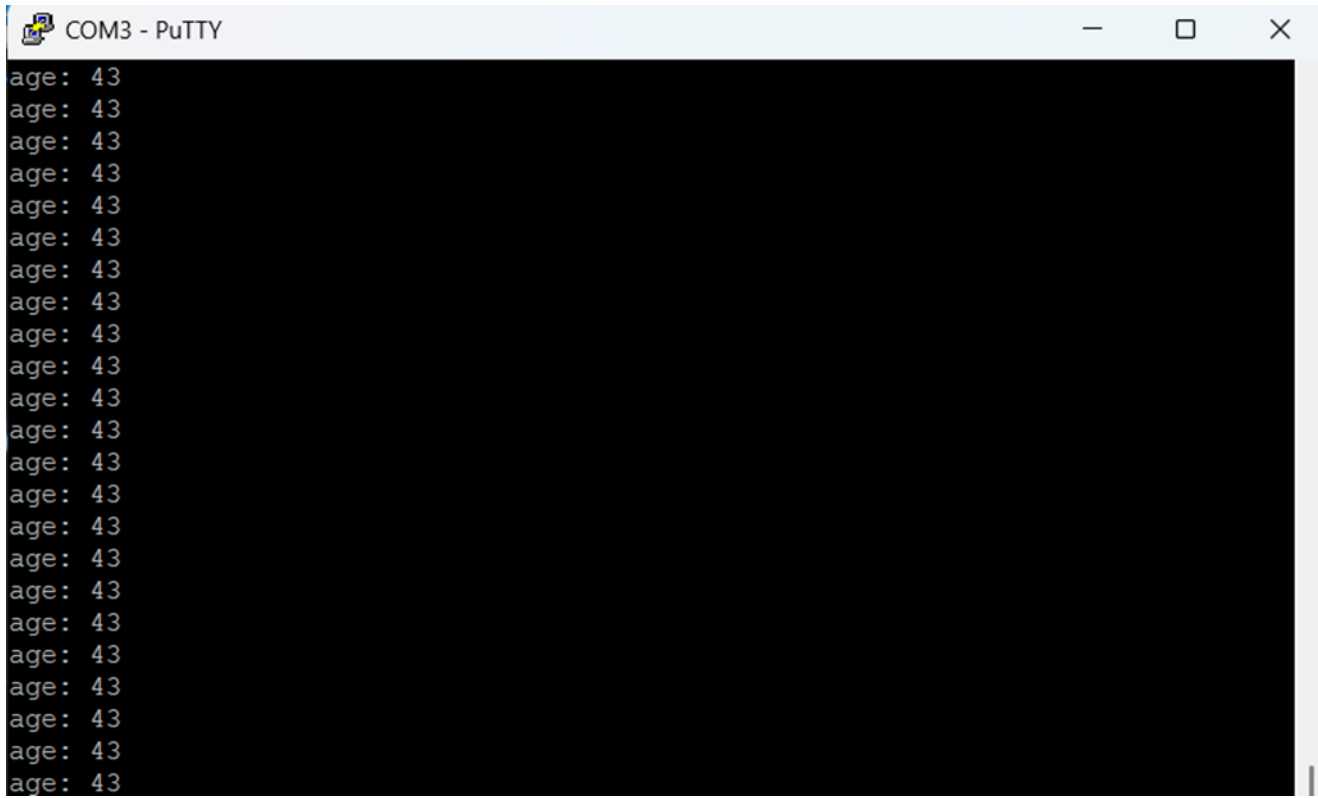
A screenshot of a PuTTY terminal window. The title bar reads "COM3 - PuTTY" and includes standard window control buttons (minimize, maximize, close). The terminal area has a black background with white text. It displays 20 identical lines, each starting with "age: 43".

```
age: 43
age: 43
age: 43
age: 43
age: 43
age: 43
age: 43
age: 43
age: 43
age: 43
age: 43
age: 43
age: 43
age: 43
age: 43
age: 43
age: 43
age: 43
age: 43
age: 43
```

In our next chapter we will debug this.

Chapter 6: Debugging Intro To Variables

Today we debug!

We will start with Ghidra.

Open up a terminal and run **ghidraRun** and when the window appears, we will select **File, New Project, Non-Shared Project, Next**, and create a **Project Name**. Here we will call it **0x0005_intro-to-variables** and press **Finish**.

Open the file explorer and navigate to the **Embedded-Hacking** folder and drag-and-drop the **0x0005_intro-to-variables.bin** file into the folder within the Ghidra application panel.

In the small window that appears, you will see the file identified as a BIN, which is a binary format without symbols. We will be using the BIN format going forward as this is what we would normally see in the wild so there will be additional setup required based on what we have learned so far.

The window will show a Raw Binary format. Here we click on the three dots to the right of Language and search for Cortex. We want to select Cortex little endian default and click **Ok**.

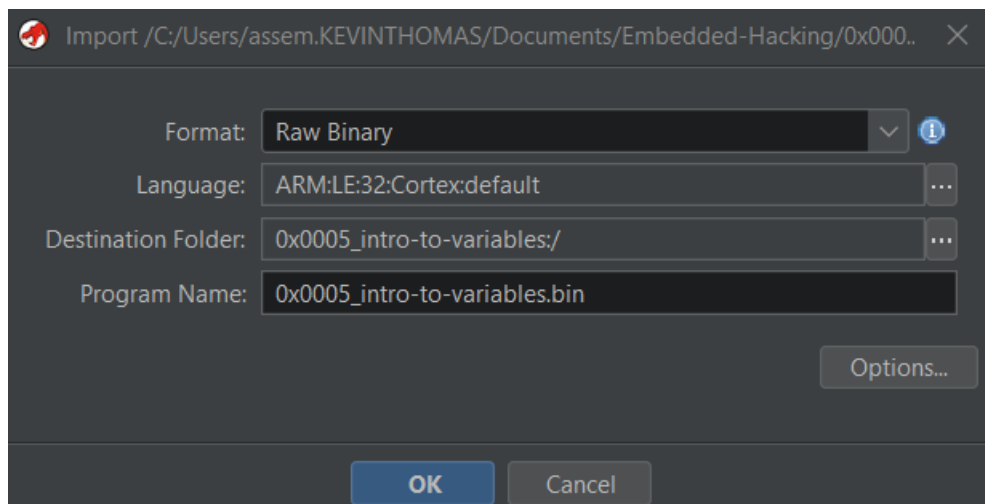

Click on the **Options...** button. Change the Block Name to **.text** and the base address to **XIP** which is **10000000** hex and click **Ok**.

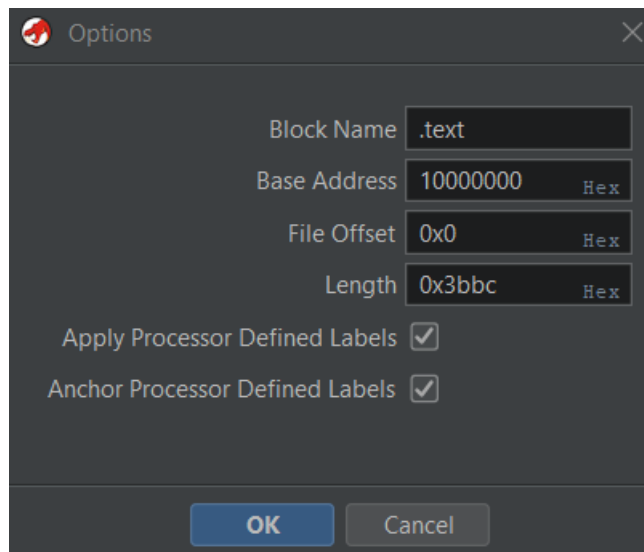

Let's double-click on the file within the window.

Finally click the auto-analyze and let's begin reviewing the binary.

Let's look at the Functions in the Symbol Tree.

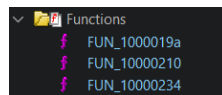

Remember back to Chapter 4, what function existed at 0x1000019a?

The answer is `data_cpy`, so now we can resolve this symbol in Ghidra.

Click on `FUN_1000019a`, in the Decompile view, click on the function name and right-click and select **Edit Function Signature**.

void `FUN_1000019a` (undefined4 param_1, undefined4 * param_2, undefined4 * param_3, undefined4 * param_4)

Function Name: `FUN_1000019a`

Calling Convention: `_stdcall`

Function Attributes:

- Varargs
- In Line
- No Return
- Use Custom Storage

Function Return/Parameters

Index	Datatype	Name	Storage
	void	<RETURN>	<VOID>
1	undefined4	param_1	r0:4
2	undefined4 *	param_2	r1:4
3	undefined4 *	param_3	r2:4
4	undefined4 *	param_4	r3:4

Call Fixup: `-NONE-`

Commit all return/parameter details

OK Cancel

Update this to `data_cpy` then click **Ok**.

Edit Function at 1000019a

```
void data_cpy (undefined4 param_1, undefined4 * param_2, undefined4 * param_3, undefined4 * param_4)
```

Function Name:

Calling Convention:

Function Attributes:

- Varargs
- In Line
- No Return
- Use Custom Storage

Function Return/Parameters

Index	Datatype	Name	Storage
	void	<RETURN>	<VOID>
1	undefined4	param_1	r0:4
2	undefined4 *	param_2	r1:4
3	undefined4 *	param_3	r2:4
4	undefined4 *	param_4	r3:4

Call Fixup:

Commit all return/parameter details

OK Cancel

In Chapter 4, what was the function at FUN_10000210.

The answer is `frame_dummy` so let's update that function as well then click **Ok**.

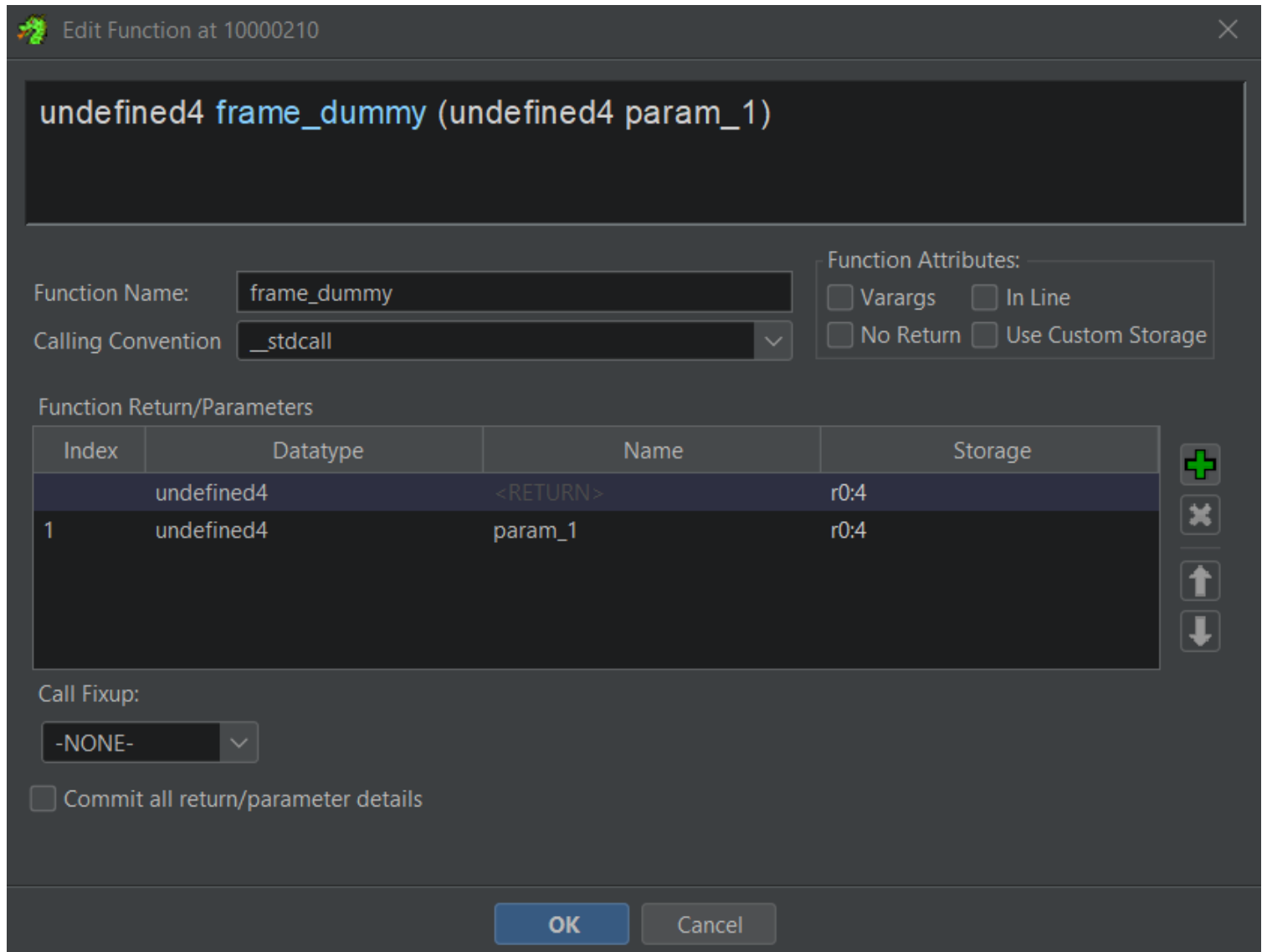

undefined4 `frame_dummy` (undefined4 `param_1`)

Function Name:

Calling Convention:

Function Attributes:

- Varargs
- In Line
- No Return
- Use Custom Storage

Function Return/Parameters

Index	Datatype	Name	Storage
	undefined4	<RETURN>	r0:4
1	undefined4	param_1	r0:4

Call Fixup:

Commit all return/parameter details

The final function we will resolve is main then click **Ok**.

int main (void)

Function Name:

Calling Convention:

Function Attributes:

- Varargs
- In Line
- No Return
- Use Custom Storage

Function Return/Parameters

Index	Datatype	Name	Storage
	int	<RETURN>	r0:4

Call Fixup:

Commit all return/parameter details

Let's review the assembler and decompile views.

The screenshot shows a debugger window with two panes. The left pane displays assembly code with addresses and instructions. The right pane shows the decompiled C code. The assembly code includes instructions like `push {r3,lr}`, `bl FUN_10002f54`, `movs r1,#0x2b`, `ldr r0=>s_age:_fd_100034a0,[DAT_10000244]`, `bl FUN_100030e4`, and `b LAB_1000023a`. The decompiled code shows a `main` function that calls `FUN_10002f54()` and `FUN_100030e4(DAT_10000244, 0x2b)` inside a `while(true)` loop.

We see two more functions that needs to be resolved. The first one is the Pico C SDK `stdio_init_all`.

If we review our source code, we see that the function returns a `bool`.

The screenshot shows a code editor with the following C code:

```
1 #include <stdio.h>
2 #inc
3
4 int
5
6
7
8
9 stdio_init_all();
10
11 while (true)
12 |   printf("age: %d\r\n", age);
13 }
14
```

A tooltip is displayed over the `stdio_init_all()` call, containing the following information:

- bool stdio_init_all(void)**
- Initialize all of the present standard stdio types that are linked into the binary.
- Returns:** true if at least one output was successfully initialized, false otherwise. `stdio_uart`, `stdio_usb`, `stdio_semihosting`, `stdio_rtt`
- [Generate Copilot summary](#)

Therefore, we need to update accordingly and click **Ok**.

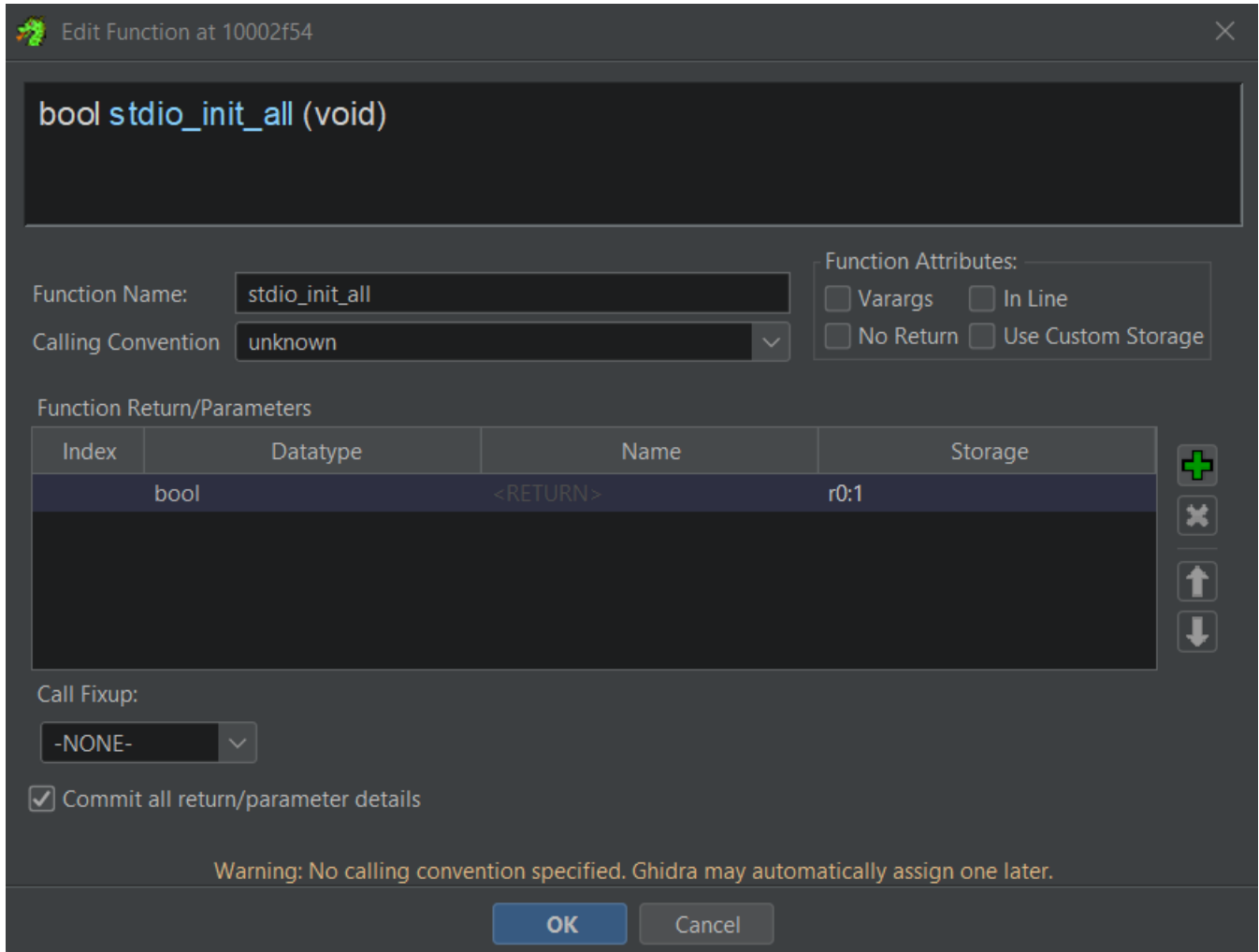

The other function we have to resolve is `printf`.

```
int printf(const char *__restrict__, ...)  
*****  
Global functions, printf  
*****  
*****  
printf()  
Function description  
print a formatted string using RTT and SEGGER RTT formatting.  
Generate Copilot summary
```

Here you want to select `Varargs` for variadic args as `printf` can take any number of args and click **Ok**.

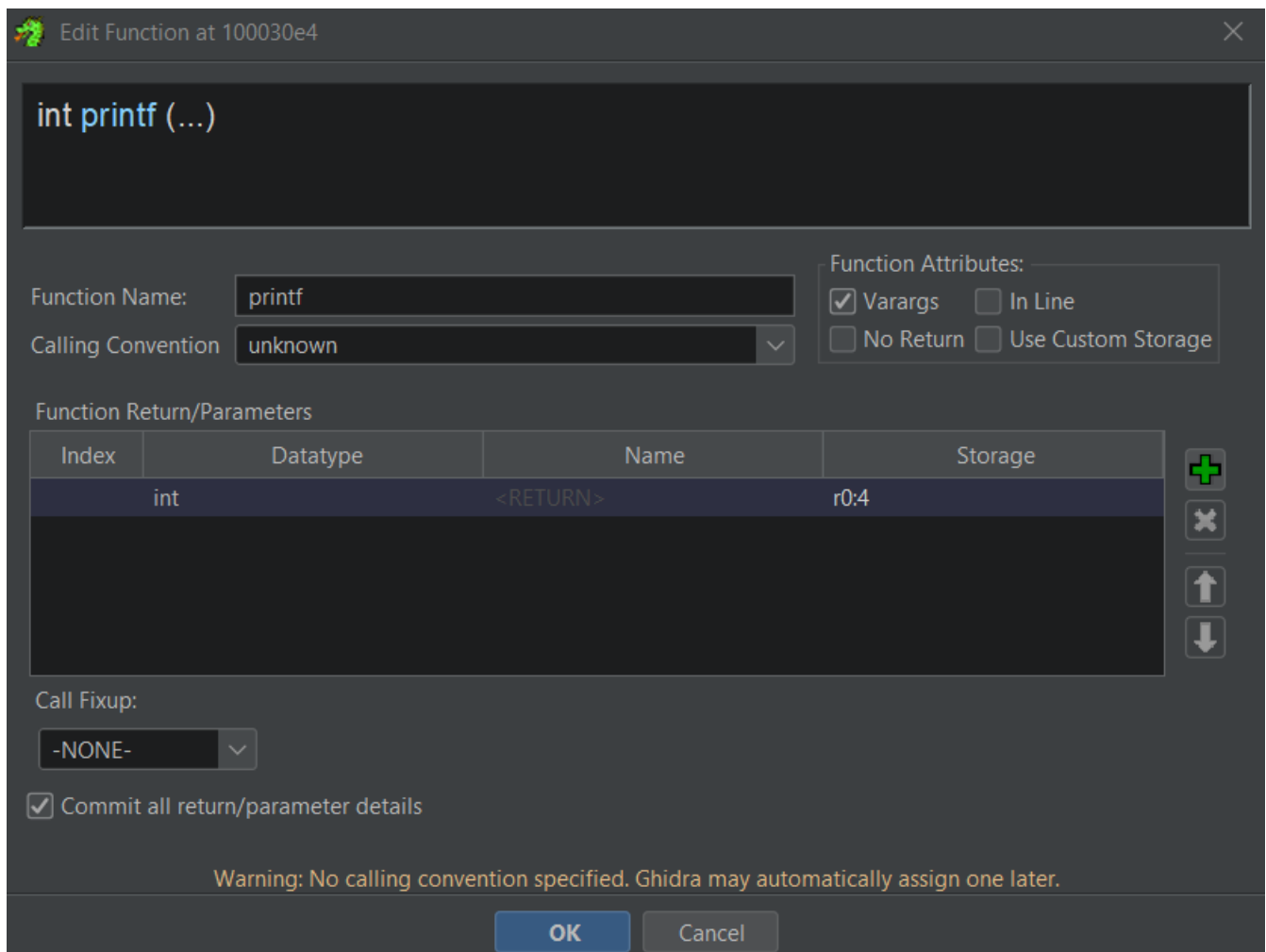

Let's reexamine our assembler and de-compilation.

```
*****...
*                               FUNCTION                               ...
*****...
int __stdcall main(void)
int r0:4 <RETURN>
main+1 XREF[1,1]: 1000018c(c), 1000018a(*)
main
10000234 08 b5 push {r3,lr}
10000236 02 f0 8d fe bl stdio_init_all bool stdio_init_all(void)
LAB_1000023a XREF[1]: 10000242(j)
1000023a 2b 21 movs r1,#0x2b
1000023c 01 48 ldr r0=>s_age:_%d_100034a0,[DAT_10000244] = "age: %d\r\n"
= 100034A0h
1000023e 02 f0 51 ff bl printf int printf(...)
10000242 fa e7 b LAB_1000023a
```

```
1
2 /* WARNING: Heritage AFTER dead
3 /* WARNING: Restarted to delay
4
5 int main(void)
6
7 {
8     undefined4 in_r0;
9
10    stdio_init_all();
11    do {
12        printf(in_r0,0x2b);
13    } while( true );
14 }
15
```

We know that 0x2b in hex is 43. We can always double-check with the ascii table that we have worked with previously.

Take note that the initialization of `uint8_t age = 42` was optimized out by the compiler so we are only seeing 43 which the original code was `age = 43`.

In our next lesson we will hack this!

Chapter 7: Hacking Intro To Variables

Let's continue where we were in Ghidra from our last chapter.



```
*****
*                               FUNCTION                               ...
*****
int __stdcall main(void)
int r0:4 <RETURN>
main+1 XREF[1,1]: 1000018c(c), 1000018a(*)
main
10000234 08 b5 push {r3,lr}
10000236 02 f0 8d fe b1 stdio_init_all bool stdio_init_all(void)
LAB_1000023a XREF[1]: 10000242(j)
1000023a 2b 21 movs r1,#0x2b
1000023c 01 48 ldr r0=>s_age:_%d_100034a0,[DAT_10000244] = "age: %d\r\n"
1000023e 02 f0 51 ff b1 printf = 100034A0h
10000242 fa e7 b LAB_1000023a int printf(...)
1
2 /* WARNING: Heritage AFTER dead
3 /* WARNING: Restarted to delay
4
5 int main(void)
6
7 {
8   undefined4 in_r0;
9
10  stdio_init_all();
11  do {
12    printf(in_r0,0x2b);
13  } while( true );
14 }
15
```

Let's hack 0x2b to 0x46! Highlight 0x2b and right-click and select **Patch Instruction**.

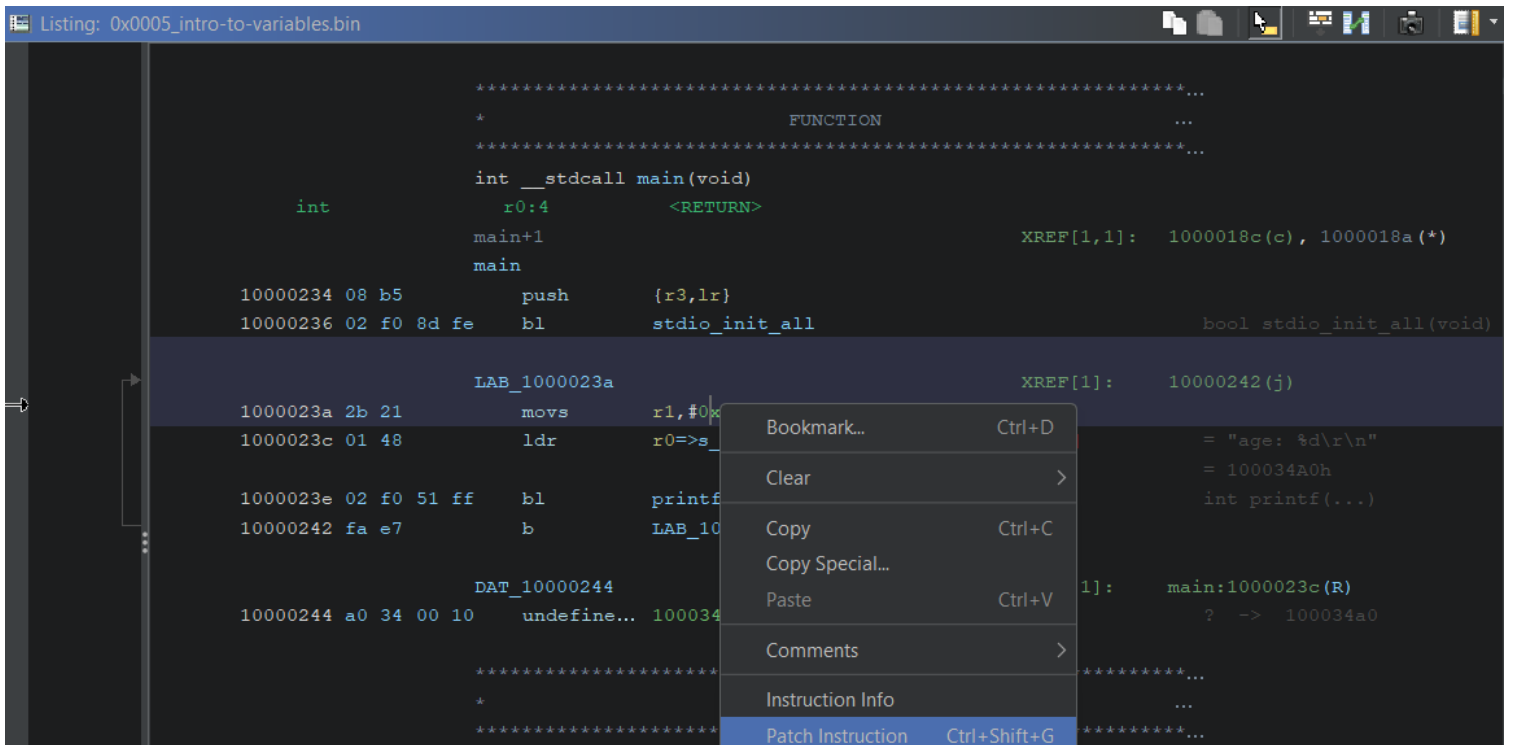

```
Listing: 0x0005_intro-to-variables.bin
*****
*                               FUNCTION                               ...
*****
int __stdcall main(void)
int r0:4 <RETURN>
main+1 XREF[1,1]: 1000018c(c), 1000018a(*)
main
10000234 08 b5 push {r3,lr}
10000236 02 f0 8d fe b1 stdio_init_all bool stdio_init_all(void)
LAB_1000023a XREF[1]: 10000242(j)
1000023a 2b 21 movs r1,#0x2b
1000023c 01 48 ldr r0=>s_age:_%d_100034a0,[DAT_10000244] = "age: %d\r\n"
1000023e 02 f0 51 ff b1 printf = 100034A0h
10000242 fa e7 b LAB_1000023a int printf(...)
DAT_10000244
10000244 a0 34 00 10 undefine... 100034
*****
*                               ...
*****
Patch Instruction Ctrl+Shift+G
```

```
LAB_1000023a XREF[1]: 10000242(j)
1000023a 46 21      movs     r1, #0x46
```

Let's export the hacked bin.

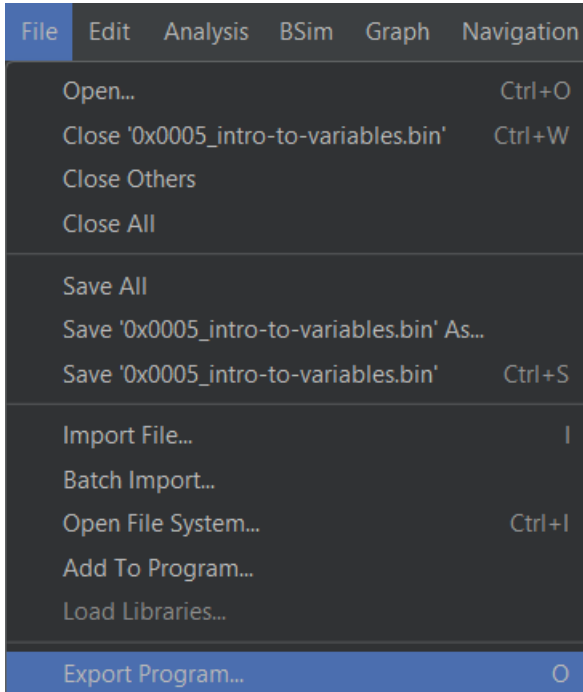

Select **Raw Bytes** as a **Format** and put the file in the **0x0005_intro-to-variables** bin directory and name the new bin **0x0005_intro-to-variables-h.bin** and click **Ok**.

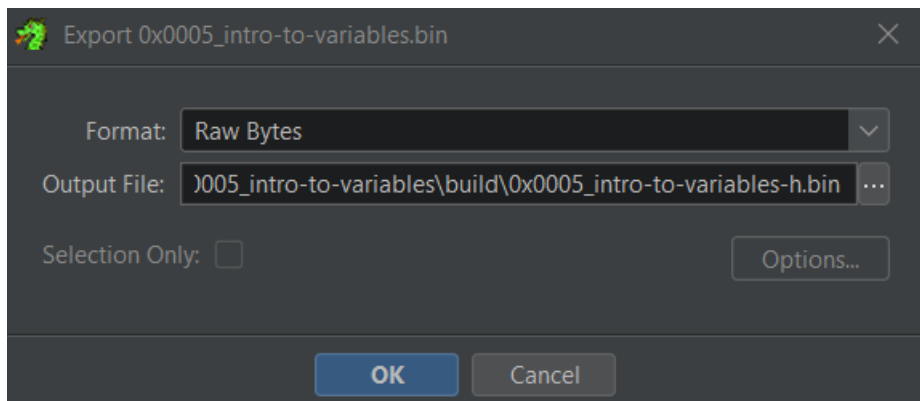

We need to use a tool to convert this hacked binary into the UF2 format.

```
python ..\uf2conv.py build\0x0005_intro-to-variables-h.bin --base 0x10000000 --family 0xe48bff59 --output build\hacked.uf2
```

After flashing the **hacked.uf2** to the Pico 2, we see the following in the serial terminal.



Boom! We hacked it!

In the coming chapters we will see a great deal of repetition so to some of you this may be a bit boring however to the majority I hope this helps to reinforce techniques that will help you beyond this course as an embedded reverse engineer.

Chapter 8: Uninitialized Variables

In this chapter we are going to examine what happens in memory when we create variables that are not initialized.

We will also introduce the RP2350 GPIO or general-purpose input/output by toggling our red LED on GPIO16.

Let's open up our folder **0x0008_uninitialized-variables**.

Now let's review our **0x0008_uninitialized-variables.c** file as this is located in the main folder.

```
#include <stdio.h>
#include "pico/stdlib.h"

#define LED_PIN 16

int main(void) {
    uint8_t age;

    stdio_init_all();

    gpio_init(LED_PIN);
    gpio_set_dir(LED_PIN, GPIO_OUT);

    while (true) {
        printf("age: %d\r\n", age);

        gpio_put(LED_PIN, 1);
        sleep_ms(500);

        gpio_put(LED_PIN, 0);
        sleep_ms(500);
    }
}
```

Let's flash the uf2 file onto the Pico. If you are unsure about this step, please take a look at Chapter 1 to get re-familiar with this process.

The only difference is that we have no idea what the value will be inside of age or do we?

In other versions of C you would see garbage data if a value is uninitialized however what we see in the C Pico SDK is that like other modern compilers, if you have a value that is not initialized, it will get assigned to the `.bss` section of memory.

The entire `.bss` section is assigned an address in RAM via the linker and does not reside in the binary or flash.

When the Pico boots, behind the scenes `memset` which is a C standard lib function is zeroing out the

entire `.bss` so this is why these values are in fact 0.

When you initialize a variable, it will go into the `.data` section.

When you initialize a constant it will go into the `.rodata` section.

Let's look at what `stdio_init_all` is behind the scenes.

```
bool stdio_init_all(void) {
    // todo add explicit custom, or registered although you can call stdio_enable_driver
    // explicitly anyway
    // These are well known ones

    bool rc = false;
#ifdef LIB_PICO_STDIO_UART
    stdio_uart_init();
    rc = true;
#endif

#ifdef LIB_PICO_STDIO_SEMIHOSTING
    stdio_semihosting_init();
    rc = true;
#endif

#ifdef LIB_PICO_STDIO_RTT
    stdio_rtt_init();
    rc = true;
#endif

#ifdef LIB_PICO_STDIO_USB
    rc |= stdio_usb_init();
#endif
    return rc;
}
```

The `gpio_init` function prepares the chosen pin for use, and `gpio_set_dir` configures it as an output so it can drive the LED. Inside the main loop, `gpio_put` is called with a value of 1 to switch the LED on and with 0 to switch it off. A call to `sleep_ms` is added between these operations to create a visible delay, producing the familiar blink effect at a human-perceivable rate.

Let's review our other 4 functions within the Pico C SDK.

```
void gpio_init(uint gpio) {
    gpio_set_dir(gpio, GPIO_IN);
    gpio_put(gpio, 0);
    gpio_set_function(gpio, GPIO_FUNC_SIO);
}
```

```

static inline void gpio_set_dir(uint gpio, bool out) {
#if PICO_USE_GPIO_COPROCESSOR
    gpioc_bit_oe_put(gpio, out);
#elif PICO_RP2040 || NUM_BANK0_GPIOS <= 32
    uint32_t mask = 1ul << gpio;
    if (out)
        gpio_set_dir_out_masked(mask);
    else
        gpio_set_dir_in_masked(mask);
#else
    uint32_t mask = 1u << (gpio & 0x1fu);
    if (gpio < 32) {
        if (out) {
            sio_hw->gpio_oe_set = mask;
        } else {
            sio_hw->gpio_oe_clr = mask;
        }
    } else {
        if (out) {
            sio_hw->gpio_hi_oe_set = mask;
        } else {
            sio_hw->gpio_hi_oe_clr = mask;
        }
    }
}
#endif
}

```

```

static inline void gpio_put(uint gpio, bool value) {
#if PICO_USE_GPIO_COPROCESSOR
    gpioc_bit_out_put(gpio, value);
#elif NUM_BANK0_GPIOS <= 32
    uint32_t mask = 1ul << gpio;
    if (value)
        gpio_set_mask(mask);
    else
        gpio_clr_mask(mask);
#else
    uint32_t mask = 1ul << (gpio & 0x1fu);
    if (gpio < 32) {
        if (value) {
            sio_hw->gpio_set = mask;
        } else {
            sio_hw->gpio_clr = mask;
        }
    } else {
        if (value) {
            sio_hw->gpio_hi_set = mask;
        } else {
            sio_hw->gpio_hi_clr = mask;
        }
    }
#endif
}

```

```

void sleep_ms(uint32_t ms) {
    sleep_us(ms * 1000ull);
}

```

Let's flash and examine the binary. We also see the red LED blinking.



In our next lesson we will debug this.

Chapter 9: Debugging Uninitialized Variables

Today we debug!

We will start with Ghidra.

Open up a terminal and run **ghidraRun** and when the window appears, we will select **File, New Project, Non-Shared Project, Next**, and create a **Project Name**. Here we will call it **0x0008_uninitialized-variables** and press **Finish**.

Open the file explorer and navigate to the **Embedded-Hacking** folder and drag-and-drop the **0x0008_uninitialized-variables.bin** file into the folder within the Ghidra application panel.

In the small window that appears, you will see the file identified as a BIN, which is a binary format without symbols. We will be using the BIN format going forward as this is what we would normally see in the wild so there will be additional setup required based on what we have learned so far.

The window will show a Raw Binary format. Here we click on the three dots to the right of language and search for Cortex. We want to select Cortex little endian default and click **Ok**.

We will skip all of the Ghidra setup as these are detailed in Chapter 6.

First, we need to set up our Cortex little-endian and options to the `.text` section to `0x10000000`.

We then auto-analyze the binary and set up the memory map as well.

We then update our function signature of `int main(void)` at `FUN_10000234`.

We then update our function signature of `bool stdio_init_all(void)` at `FUN_100030cc`.

We then update our function signature of `void gpio_init(uint gpio)` at `FUN_100002b4`.

```
10000240 4f f0 01 05    mov.w    r5,#0x1
10000244 10 23           movs    r3,#0x10
10000246 45 ec 44 30    mcrr    p0,0x4,r3,r5,cr4
```

The `gpioc_bit_out_put` is a tiny, always-inlined helper that atomically sets or clears a single GPIO by emitting a coprocessor instruction: it calls `pico_default_asm_volatile("mcrr p0, #4, %0, %1, c0" :: "r"(pin), "r"(val))`, passing the pin number and the boolean value to the RP2 GPIO coprocessor; the effect is equivalent to `"if (val) gpioc_hilo_out_set(1ull << pin); else gpioc_hilo_out_clr(1ull << pin)"`, so a true value sets the pin, false clears it, and the operation happens in one atomic coprocessor-backed cycle.

```

static inline void gpio_set_dir(uint gpio, bool out) {
#if PICO_USE_GPIO_COPROCESSOR
    gpioc_bit_oe_put(gpio, out);
#elif PICO_RP2040 || NUM_BANK0_GPIOS <= 32
    uint32_t mask = 1ul << gpio;
    if (out)
        gpio_set_dir_out_masked(mask);
    else
        gpio_set_dir_in_masked(mask);
#else
    uint32_t mask = 1u << (gpio & 0x1fu);
    if (gpio < 32) {
        if (out) {
            sio_hw->gpio_oe_set = mask;
        } else {
            sio_hw->gpio_oe_clr = mask;
        }
    } else {
        if (out) {
            sio_hw->gpio_hi_oe_set = mask;
        } else {
            sio_hw->gpio_hi_oe_clr = mask;
        }
    }
}
#endif
}

```

We have worked with Ghidra and GDB. Let's take another perspective working with our GPIO and LED by first looking at that raw code. We have **0x0008_uninitialized-variables-a.c** so let's review.

```

#include <stdio.h>
#include "pico/stdlib.h"

#define LED_PIN 16

int main(void)
{
    gpio_init(LED_PIN);
    gpio_set_dir(LED_PIN, GPIO_OUT);

    while (true) {
        gpio_put(LED_PIN, 1);
        sleep_ms(500);

        gpio_put(LED_PIN, 0);
        sleep_ms(500);
    }
}

```

Let's take a step deeper.

We have **0x0008_uninitialized-variables-b.c** so let's review.

```
#include <stdio.h>
#include "pico/stdlib.h"

#define LED_PIN 16

int main(void)
{
    // gpio_init(LED_PIN);
    gpio_set_dir(LED_PIN, GPIO_IN);
    gpio_put(LED_PIN, 0);
    gpio_set_function(LED_PIN, GPIO_FUNC_SIO);

    // gpio_set_dir(LED_PIN, GPIO_OUT);
    gpioc_bit_oe_put(LED_PIN, GPIO_OUT);

    while (true) {
        // gpio_put(LED_PIN, 1);
        gpioc_bit_out_put(LED_PIN, 1);
        // sleep_ms(500);
        sleep_us(500 * 1000ull);

        // gpio_put(LED_PIN, 0);
        gpioc_bit_out_put(LED_PIN, 0);
        // sleep_ms(500);
        sleep_us(500 * 1000ull);
    }
}
```

Here we see some additional internal sdk functions. Let's dig deeper to have a better understanding of what is going on.

We have **0x0008_uninitialized-variables-c.c** so let's review.

```
#include <stdio.h>
#include "pico/stdlib.h"

#define LED_PIN 16

int main(void)
{
    // gpio_init(LED_PIN);
    /// gpio_set_dir(LED_PIN, GPIO_IN);
    gpioc_bit_oe_put(LED_PIN, GPIO_OUT);
    /// gpio_put(LED_PIN, 0);
    gpioc_bit_out_put(LED_PIN, 0);
    /// gpio_set_function(LED_PIN, GPIO_FUNC_SIO);
    hw_write_masked(&pads_bank0_hw->io[LED_PIN],
                   PADS_BANK0_GPIO0_IE_BITS,
                   PADS_BANK0_GPIO0_IE_BITS | PADS_BANK0_GPIO0_OD_BITS
    );
    io_bank0_hw->io[LED_PIN].ctrl = GPIO_FUNC_SIO << IO_BANK0_GPIO0_CTRL_FUNCSEL_LSB;
    hw_clear_bits(&pads_bank0_hw->io[LED_PIN], PADS_BANK0_GPIO0_ISO_BITS);

    // gpio_set_dir(LED_PIN, GPIO_OUT);
    gpioc_bit_oe_put(LED_PIN, GPIO_OUT);

    while (true) {
        // gpio_put(LED_PIN, 1);
        gpioc_bit_out_put(LED_PIN, 1);
        // sleep_ms(500);
        sleep_us(500 * 1000ull);

        // gpio_put(LED_PIN, 0);
        gpioc_bit_out_put(LED_PIN, 0);
        // sleep_ms(500);
        sleep_us(500 * 1000ull);
    }
}
```

Here we see some more lower-level activity that we will review at the assembler level.

We have **0x0008_uninitialized-variables-b.d** so let's review.

```
#include <stdio.h>
#include "pico/stdlib.h"

#define LED_PIN 16

int main(void)
{
    // gpio_init(LED_PIN);
    // gpio_set_dir(LED_PIN, GPIO_IN);
    // gpio_set_dir(LED_PIN, GPIO_OUT);
    pico_default_asm_volatile ("mcr p0, #4, %0, %1, c4" : : "r" (LED_PIN), "r"
(GPIO_OUT));
    // gpio_put(LED_PIN, 0);
    // gpio_set_dir(LED_PIN, GPIO_OUT);
    pico_default_asm_volatile ("mcr p0, #4, %0, %1, c4" : : "r" (LED_PIN), "r"
(GPIO_OUT));
    // gpio_set_function(LED_PIN, GPIO_FUNC_SIO);
    // hw_write_masked(&pads_bank0_hw->io[LED_PIN],
    //                 PADS_BANK0_GPIO0_IE_BITS,
    //                 PADS_BANK0_GPIO0_IE_BITS | PADS_BANK0_GPIO0_OD_BITS
    //                 );
    // hw_xor_bits(addr, (*addr ^ values) & write_mask);
    pico_default_asm_volatile (
        "ldr r2, [%0]\n"           // load current pad register
        "eor r2, r2, %1\n"        // xor with IE bit
        "and r2, r2, %2\n"        // mask with (IE|OD)
        "eor r2, r2, %1\n"        // recombine (hw_xor_bits logic)
        "str r2, [%0]\n"         // write back
        :
        : "r" (&pads_bank0_hw->io[LED_PIN]),
        "r" (PADS_BANK0_GPIO0_IE_BITS),
        "r" (PADS_BANK0_GPIO0_IE_BITS | PADS_BANK0_GPIO0_OD_BITS)
        : "r2", "memory"
    );

    // io_bank0_hw->io[LED_PIN].ctrl = GPIO_FUNC_SIO << IO_BANK0_GPIO0_CTRL_FUNCSEL_LSB;
    pico_default_asm_volatile (
        "str %1, [%0]\n"
        :
        : "r" (&io_bank0_hw->io[LED_PIN].ctrl),
        "r" (GPIO_FUNC_SIO << IO_BANK0_GPIO0_CTRL_FUNCSEL_LSB)
        : "memory"
    );
    // hw_clear_bits(&pads_bank0_hw->io[LED_PIN], PADS_BANK0_GPIO0_ISO_BITS);
    pico_default_asm_volatile (
        "ldr r2, [%0]\n"           // load current register value
        "bic r2, r2, %1\n"        // clear the ISO bits (bit clear)
        "str r2, [%0]\n"         // write back
        :
        : "r" (&pads_bank0_hw->io[LED_PIN]),
        "r" (PADS_BANK0_GPIO0_ISO_BITS)
        : "r2", "memory"
    );
};
```

```

// gpio_set_dir(LED_PIN, GPIO_OUT);
/// gpioc_bit_oe_put(LED_PIN, GPIO_OUT);
pico_default_asm_volatile ("mcrn p0, #4, %0, %1, c4" : : "r" (LED_PIN), "r"
(GPIO_OUT));

while (true) {
    // gpio_put(LED_PIN, 1);
    /// gpioc_bit_out_put(LED_PIN, 1);
    pico_default_asm_volatile ("mcrn p0, #4, %0, %1, c0" : : "r" (LED_PIN), "r" (1));
    /// sleep_ms(500);
    sleep_us(500 * 1000ull);

    // gpio_put(LED_PIN, 0);
    /// gpioc_bit_out_put(LED_PIN, 0);
    pico_default_asm_volatile ("mcrn p0, #4, %0, %1, c0" : : "r" (LED_PIN), "r" (0));
    /// sleep_ms(500);
    sleep_us(500 * 1000ull);
}
}

```

Here we start to dive into assembler, let's review in our next and final deeper dive.

We have **0x0008_uninitialized-variables-e.e** so let's review.

```
int main(void) {
    __asm__ volatile (
        // gpio_init(LED_PIN);
        // gpio_set_dir(LED_PIN, GPIO_IN);
        // gpio_bit_oe_put(LED_PIN, GPIO_OUT);
        "movs r4, #0x10\n"           // GPIO16
        "movs r5, #0x01\n"         // bit 1; used for OUT/OE writes
        "mcr r p0, #4, r4, r5, c4\n" // gpio_bit_oe_put(16, 1); p102

        // gpio_set_function(LED_PIN, GPIO_FUNC_SIO);
        // hw_write_masked(&pads_bank0_hw->io[LED_PIN],
        //                 PADS_BANK0_GPIO0_IE_BITS,
        //                 PADS_BANK0_GPIO0_IE_BITS | PADS_BANK0_GPIO0_OD_BITS
        // );
        // hw_xor_bits(addr, (*addr ^ values) & write_mask);
        "ldr r3, =0x40038044\n"     // &pads_bank0_hw->io[16]; p785, p796
        "ldr r2, [r3]\n"           // load current config
        "bic r2, r2, #0x80\n"      // clear OD; output disable
        "orr r2, r2, #0x40\n"      // set IE; enable input buffer
        "str r2, [r3]\n"           // store updated config
        // io_bank0_hw->io[LED_PIN].ctrl = GPIO_FUNC_SIO <<
        IO_BANK0_GPIO0_CTRL_FUNCSEL_LSB;
        "ldr r3, =0x40028084\n"     // &io_bank0_hw->io[16].ctrl; p603, p637
        "ldr r2, [r3]\n"           // load current config
        "bic r2, r2, #0x1f\n"      // clear FUNCSEL bits [4:0]
        "orr r2, r2, #5\n"         // set FUNCSEL = 5 (SIO)
        "str r2, [r3]\n"           // store updated config
        // hw_clear_bits(&pads_bank0_hw->io[gpio], PADS_BANK0_GPIO0_ISO_BITS);
        "ldr r3, =0x40038044\n"     // &pads_bank0_hw->io[16]; p785, p796
        "ldr r2, [r3]\n"           // load current config
        "bic r2, r2, #0x100\n"     // clear ISO bit (bit 8) un-isolate pad
        "str r2, [r3]\n"           // store updated config

        // gpio_set_dir(LED_PIN, GPIO_OUT);
        // gpio_bit_oe_put(LED_PIN, GPIO_OUT);
        "movs r4, #0x10\n"           // GPIO16
        "movs r5, #0x01\n"         // bit 1; used for OUT/OE writes
        "mcr r p0, #4, r4, r5, c4\n" // gpio_bit_oe_put(16, 1); p102

        // while (true)
        "1:\n"                       // loop start

        // gpio_put(LED_PIN, 1);
        // gpio_bit_out_put(LED_PIN, 1);
        "movs r4, #0x10\n"           // GPIO16
        "movs r5, #0x01\n"         // bit 1; used for OUT/OE writes
        "mcr r p0, #4, r4, r5, c0\n" // gpio_bit_out_put(16, 1)
        // sleep_ms(500);
        // sleep_us(500 * 1000ull);
        "ldr r2, =0x17D7840\n"     // r2 = ~8.4M cycles
        "2:\n"                       // delay loop
        "subs r2, r2, #1\n"         // decrement counter
        "bne 2b\n"                 // repeat until zero
    );
}
```

```

// gpio_put(LED_PIN, 1);
/// gpioc_bit_out_put(LED_PIN, 1);
"movs r4, #0x10\n" // GPIO16
"movs r5, #0x00\n" // bit 0; used for OUT/OE writes
"mcrn p0, #4, r4, r5, c0\n" // gpioc_bit_out_put(16, 0)
// sleep_ms(500);
/// sleep_us(500 * 1000u11);
"ldr r2, =0x17D7840\n" // r2 = ~8.4M cycles
"3:\n" // delay loop
"subs r2, r2, #1\n" // decrement counter
"bne 3b\n" // repeat until zero

// jmp
"b 1b\n" // repeat forever
);
}

```

This code demonstrates a complete GPIO blink implementation for the RP2350 microcontroller using inline assembly with GPIO coprocessor instructions. The program initializes GPIO pin 16 as an output and creates an infinite loop that toggles the pin state every 500 milliseconds. The code leverages RP2350-specific features, particularly the GPIO coprocessor accessible through `mcrn p0, #4` instructions, which provides efficient hardware-accelerated GPIO control that wasn't available on the earlier RP2040 chip.

The initialization sequence follows the standard GPIO setup pattern but uses direct register manipulation for maximum performance. First, it configures the pad control register at address `0x40038044` (`PADS_BANK0_BASE + 0x44` for GPIO16) to enable input buffering and disable output disable functionality. Then it sets the GPIO function to SIO (Software I/O) by writing value 5 to the `IO_BANK0` control register at `0x40028084`, and removes pad isolation by clearing bit 8. Finally, it uses the GPIO coprocessor to enable output mode for the pin.

The main blink loop demonstrates precise timing control using a software delay loop calibrated for the RP2350's 150MHz system clock. The delay value `0x17D7840` (approximately 25 million iterations) is calculated to produce a 500ms delay, accounting for the loop overhead of roughly 3 CPU cycles per iteration. The loop alternates between setting GPIO16 high and low using the coprocessor instructions `mcrn p0, #4, r4, r5, c0`, where the coprocessor efficiently handles the bit manipulation without requiring traditional memory-mapped I/O operations. This approach provides deterministic timing and minimal CPU overhead compared to using the standard SDK GPIO functions.

In our next chapter we will hack this.

Chapter 10: Hacking Uninitialized Variables

Today we hack!

We will start with Ghidra.

Let's open our **0x0008_uninitialized-variables** project.

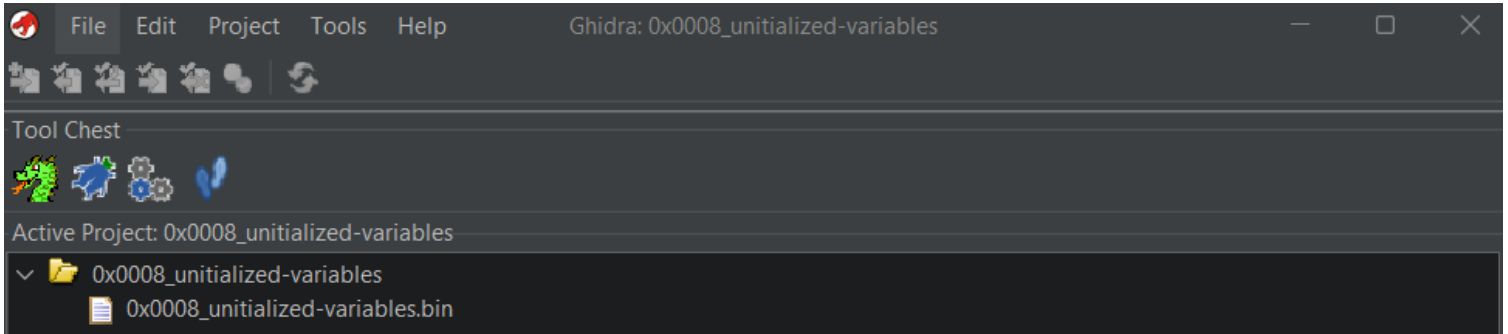

In our last chapter we resolved some of the functions such as `main`.

```
***** ...
*                FUNCTION                ...
***** ...

int __stdcall main(void)
int      r0:4    <RETURN>
main+1   XREF[1,1]: 1000018c (c), 1000018a (*)
main
10000234 38 b5      push   {r3,r4,r5,lr}
10000236 02 f0 49 ff  bl     stdio_init_all      bool stdio_init_all(void)
1000023a 10 20      movs  r0,#0x10
1000023c 00 f0 3a f8  bl     gpio_init        void gpio_init(uint gpio)
10000240 4f f0 01 05  mov.w  r5,#0x1
10000244 10 23      movs  r3,#0x10
10000246 45 ec 44 30  mcrr  p0,0x4,r3,r5,cr4

LAB_1000024a XREF[1]: 10000270 (j)
1000024a 00 21      movs  r1,#0x0
1000024c 09 48      ldr   r0=>s_age:_%d_10003618,[DAT_10000274] = "age: %d\r\n"
                                                = 10003618h
1000024e 03 f0 05 f8  bl     FUN_1000325c      undefined FUN_1000325c()
10000252 10 24      movs  r4,#0x10
10000254 45 ec 40 40  mcrr  p0,0x4,r4,r5,cr0
10000258 4f f4 fa 70  mov.w  r0,#0x1f4
1000025c 00 f0 58 fd  bl     FUN_10000d10      undefined FUN_10000d10()
10000260 4f f0 00 03  mov.w  r3,#0x0
10000264 43 ec 40 40  mcrr  p0,0x4,r4,r3,cr0
10000268 4f f4 fa 70  mov.w  r0,#0x1f4
1000026c 00 f0 50 fd  bl     FUN_10000d10      undefined FUN_10000d10()
10000270 eb e7      b     LAB_1000024a
```

We know that in our last chapter we enabled GPIO 16 and it blinked the red LED.

The first thing we will hack is instead of GPIO 16 we will make GPIO 17 blink.

The first thing we need to patch is the following.

```
1000023a 10 20          movs      r0,#0x10
```

Here we will patch this to 0x11 which is 17 in decimal.

In earlier chapters we went over this in detail so the first thing we will do is **right-click** on the instruction, select **Patch Instruction** and change 0x10 to 0x11.

That corresponds with us calling the `gpio_init(LED_PIN)` code from our source.

We also have to patch the following.

```
10000240 4f f0 01 05      mov.w    r5,#0x1
10000244 10 23          movs      r3,#0x10
10000246 45 ec 44 30      mcrr     p0,0x4 ,r3,r5,cr4
```

Here, we will **right-click** and **Patch Instruction** 0x10 to 0x11 as well.

These lines correspond to `gpio_set_dir(LED_PIN, GPIO_OUT)` code from our source.

Now we are going to enter into our loop.

Let's hack the 0x0 to say 0x42. We will do the same patch instruction as we did earlier.

```
1000024a 00 21          movs      r1,#0x0
```

We also have to patch our GPIO in the below line to 0x11.

```
10000252 10 24          movs      r4,#0x10
```

At this point we can click **File, Export Program, select Format: Raw Bytes** and update our output file to **0x0008_unitialized-variables-h.bin** and click **Ok**.

Finally, we have to convert to a UF2.

```
python ..\uf2conv.py build\0x0008_unitialized-variables-h.bin --base 0x10000000 --family 0xe48bff59 --output build\hacked.uf2
```

Let's flash our Pico 2 and we will notice the green LED blinking so YAY!

If we open up PuTTY or another terminal program, we will see 0x42 or 66 decimal as well. BOOM!

A screenshot of a PuTTY terminal window. The title bar at the top reads "COM3 - PuTTY" and includes standard window control buttons (minimize, maximize, close). The terminal area is black with white text. It displays 20 identical lines of text: "age: 66".

```
age: 66
age: 66
age: 66
age: 66
age: 66
age: 66
age: 66
age: 66
age: 66
age: 66
age: 66
age: 66
age: 66
age: 66
age: 66
age: 66
age: 66
age: 66
age: 66
age: 66
```

In our next lesson we will cover the integer data type.

Chapter 11: Integer Data Type

In this chapter we are going to discuss the integer data type. We have already covered examples with this however the goal of this course is to continue to reinforce learning so that you have a mastery of the embedded process.

Let's open up our folder **0x000b_integer-data-type**.

Now let's review our **0x000b_integer-data-type.c** file as this is located in the main folder.

```
#include <stdio.h>
#include "pico/stdlib.h"

int main(void) {
    uint8_t age = 43;
    int8_t range = -42;

    stdio_init_all();

    __asm volatile (
        "ldr r3, =0x40038000\n"           // address of PADS_BANK0_BASE
        "ldr r2, =0x40028004\n"         // address of IO_BANK0 GPIO0.ctrl
        "movs r0, #16\n"                // GPIO16 (start pin)

        "init_loop:\n"                 // loop start
        "lsls r1, r0, #2\n"             // pin * 4 (pad offset)
        "adds r4, r3, r1\n"             // PADS base + offset
        "ldr r5, [r4]\n"                // load current config
        "bic r5, r5, #0x180\n"          // clear OD+ISO
        "orr r5, r5, #0x40\n"           // set IE
        "str r5, [r4]\n"                // store updated config

        "lsls r1, r0, #3\n"             // pin * 8 (ctrl offset)
        "adds r4, r2, r1\n"             // IO_BANK0 base + offset
        "ldr r5, [r4]\n"                // load current config
        "bic r5, r5, #0x1f\n"           // clear FUNCSEL bits [4:0]
        "orr r5, r5, #5\n"              // set FUNCSEL = 5 (SIO)
        "str r5, [r4]\n"                // store updated config

        "mov r4, r0\n"                  // pin
        "movs r5, #1\n"                 // bit 1; used for OUT/OE writes
        "mcrnr p0, #4, r4, r5, c4\n"    // gpioc_bit_oe_put(pin,1)
        "adds r0, r0, #1\n"             // increment pin
        "cmp r0, #20\n"                 // stop after pin 18
        "blt init_loop\n"               // loop until r0 == 20
    );
```

```

uint8_t pin = 16;

while (1) {
    __asm volatile (
        "mov r4, %0\n"           // pin
        "movs r5, #0x01\n"      // bit 1; used for OUT/OE writes
        "mcrp p0, #4, r4, r5, c0\n" // gpioc_bit_out_put(16, 1)
        :
        : "r"(pin)
        : "r4","r5"
    );
    sleep_ms(500);

    __asm volatile (
        "mov r4, %0\n"           // pin
        "movs r5, #0\n"         // bit 0; used for OUT/OE writes
        "mcrp p0, #4, r4, r5, c0\n" // gpioc_bit_out_put(16, 0)
        :
        : "r"(pin)
        : "r4","r5"
    );
    sleep_ms(500);

    pin++;
    if (pin > 18) pin = 16;

    printf("age: %d\r\n", age);
    printf("range: %d\r\n", range);
}
}

```

Here we have a heavy mix of inline assembler and C. We start off with a `uint8_t` `age = 43` which is an unsigned 8-bit integer which is 43 and an `int8_t` `range = -42` which is 42.

We then init our `stdio_init_all` for the purposes of our UART terminal interface.

Let's take a moment and explain UART. Universal Asynchronous Receiver Transmitter is what we use to communicate with our terminal. Up to this point it has only been in a receive capacity where we are only receiving print statements rather than being interactive.

On the RP2350, the UART is one of the chip's flexible serial interfaces, designed for simple, low-pin-count communication between the microcontroller and external devices such as PCs, sensors, or other MCUs. Each UART block handles full-duplex communication with independent transmit (TX) and receive (RX) FIFOs for efficient data handling. Like other RP-series chips, the RP2350 uses a GPIO muxing system, so any eligible GPIO pin can be mapped to a UART function, giving developers freedom in board layout. The UART supports standard features such as configurable word length, stop bits, parity, and flow control for general-purpose serial communication in embedded applications.

We have GPIO 0 which on the board is our UART0 TX pin connected to our Pico Debug Probe's UART RX pin. In addition, we have our GPIO 1 pin on the board which is UART0 RX pin connected to our Debug Probe's UART TX pin so we can have communication.

We will explore UART in more depth in future chapters.

After we init our `stdio_init_all` which will in our case enable UART communications, we have a larger inline assembler block.

Here we load the hardware addresses of `0x4003800` which is the `PADS_BANK0_BASE` address we saw in the RP2350 datasheet from prior chapters.

```
"ldr r3, =0x40038000\n"           // address of PADS_BANK0_BASE
```

On page 32 of the datasheet, we see it clearly.

RP2350 Datasheet

Bus Endpoint	Base Address
CLOCKS_BASE	0x40010000
PSM_BASE	0x40018000
RESETS_BASE	0x40020000
IO_BANK0_BASE	0x40028000
IO_QSPI_BASE	0x40030000
PADS_BANK0_BASE	0x40038000

If we turn to page 595 of the datasheet, we see more info on pads.

Each GPIO is connected off-chip via a **pad**. Pads are the electrical interface between the chip's internal logic and external circuitry. They translate signal voltage levels, support higher currents and offer some protection against electrostatic discharge (ESD) events. You can adjust pad electrical behaviour to meet the requirements of external circuitry in the following ways:

- Output drive strength can be set to 2mA, 4mA, 8mA or 12mA.
- Output slew rate can be set to slow or fast.
- Input hysteresis (Schmitt trigger mode) can be enabled.
- A pull-up or pull-down can be enabled, to set the output signal level when the output driver is disabled.
- The input buffer can be disabled, to reduce current consumption when the pad is unused, unconnected or connected to an analogue signal.

An example pad is shown in [Figure 42](#).

Figure 42. Diagram of a single IO pad.

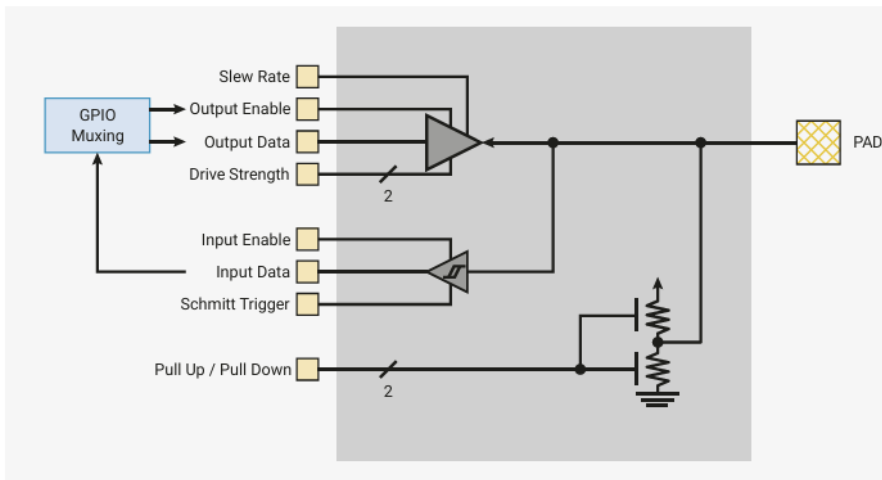

The next line of assembler is the address of `IO_BANK0`, `GPIO0_CTRL`.

```
"ldr r2, =0x40028004\n" // address of IO_BANK0 GPIO0.ctrl
```

On page 604-605 of the datasheet, we see this info.

9.11. List of registers

9.11.1. IO - User Bank

The User Bank IO registers start at a base address of `0x40028000` (defined as `IO_BANK0_BASE` in SDK).

Table 649. List of IO_BANK0 registers

Offset	Name	Info
0x000	GPIO0_STATUS	
0x004	GPIO0_CTRL	

Here we see at offset 0x4, the CTRL value we are looking for as we can now dig into this 32-bit wide register on page 610 of the datasheet.

IO_BANK0: GPIO0_CTRL Register

Offset: 0x004

Table 651.
GPIO0_CTRL Register

Bits	Description	Type	Reset
31:30	Reserved.	-	-
29:28	IRQOVER	RW	0x0
	Enumerated values:		
	0x0 → NORMAL: don't invert the interrupt		
	0x1 → INVERT: invert the interrupt		
	0x2 → LOW: drive interrupt low		
	0x3 → HIGH: drive interrupt high		
27:18	Reserved.	-	-
17:16	INOVER	RW	0x0
	Enumerated values:		
	0x0 → NORMAL: don't invert the peri input		
	0x1 → INVERT: invert the peri input		
	0x2 → LOW: drive peri input low		
	0x3 → HIGH: drive peri input high		

Bits	Description	Type	Reset
	0x2 → LOW: drive output low		
	0x3 → HIGH: drive output high		
11:5	Reserved.	-	-
4:0	FUNCSEL : 0-31 → selects pin function according to the gpio table 31 == NULL	RW	0x1f
	Enumerated values:		
	0x00 → JTAG_TCK		
	0x01 → SPI0_RX		
	0x02 → UART0_TX		
	0x03 → I2C0_SDA		
	0x04 → PWM_A_0		
	0x05 → SIO_0		
	0x06 → PIO0_0		
	0x07 → PIO1_0		
	0x08 → PIO2_0		
	0x09 → XIP_SS_N_1		
	0x0a → USB_MUXING_OVERCURR_DETECT		
	0x1f → NULL		

Here we see all of the bits within the 32-bit register that we can configure.

The next assembler code line is moving the value of 16 into the r0 register.

```
movs r0, #16\n" // GPIO16 (start pin)
```

This is the address of our start LED start pin.

Let's review our assembler.

```

__asm volatile (
    "ldr r3, =0x40038000\n"           // address of PADS_BANK0_BASE
    "ldr r2, =0x40028004\n"         // address of IO_BANK0 GPIO0.ctrl
    "movs r0, #16\n"                // GPIO16 (start pin)

    "init_loop:\n"                  // loop start
    "lsls r1, r0, #2\n"             // pin * 4 (pad offset)
    "adds r4, r3, r1\n"             // PADS base + offset
    "ldr r5, [r4]\n"                // load current config
    "bic r5, r5, #0x180\n"          // clear OD+ISO
    "orr r5, r5, #0x40\n"           // set IE
    "str r5, [r4]\n"                // store updated config

    "lsls r1, r0, #3\n"             // pin * 8 (ctrl offset)
    "adds r4, r2, r1\n"             // IO_BANK0 base + offset
    "ldr r5, [r4]\n"                // load current config
    "bic r5, r5, #0x1f\n"           // clear FUNCSEL bits [4:0]
    "orr r5, r5, #5\n"              // set FUNCSEL = 5 (SIO)
    "str r5, [r4]\n"                // store updated config

    "mov r4, r0\n"                  // pin
    "movs r5, #1\n"                 // bit 1; used for OUT/OE writes
    "mcrnr p0, #4, r4, r5, c4\n"    // gpioctl_oe_put(pin,1)
    "adds r0, r0, #1\n"             // increment pin
    "cmp r0, #20\n"                 // stop after pin 18
    "btl init_loop\n"               // loop until r0 == 20
);

```

This inline assembly routine is walking through GPIO pins 16–18 on our RP2350 and configuring them for direct software control via the SIO (single-cycle I/O) block. For each pin, it first accesses the PADS_BANK0 register set to clear the output-disable/isolation bits and enable the input buffer, ensuring the pad is electrically active. Then it moves to the IO_BANK0 control register for that pin, clears the function select field, and sets it to 5, which maps the pin to the SIO peripheral rather than an alternate function. Finally, it uses a coprocessor register write (`mcrnr`) to enable the output driver for that pin. The loop increments through pins 16–18, so by the end, those three GPIOs are initialized as standard digital I/O lines under SIO control, ready for bit-banging or direct register-driven toggling.

Why do we have a compare to 20 as we are only dealing with GPIO 16-18?

```
"cmp r0, #20\n" // stop after pin 18
```

This comes down to how the loop termination works. The instruction `cmp r0, #20` is paired with `btl init_loop`, which means “branch back while **r0 < 20**.” Since you start at `r0 = 16`, the loop runs for 16, 17, 18, 19. That gives you four iterations, and GPIO18 gets configured on the third pass (when `r0 = 18`). If you instead compared against 19, the loop would only run while `r0 < 19`, so it would stop after finishing `r0 = 17` therefore never reaching 18. In other words, the compare value is always set to one past the last pin you want, because the branch condition checks for “less than,” not “less than or equal.”

We see the red, green and yellow LED’s toggling every 500ms and we see in our terminal the values of our integer values printing in the same timeframe.

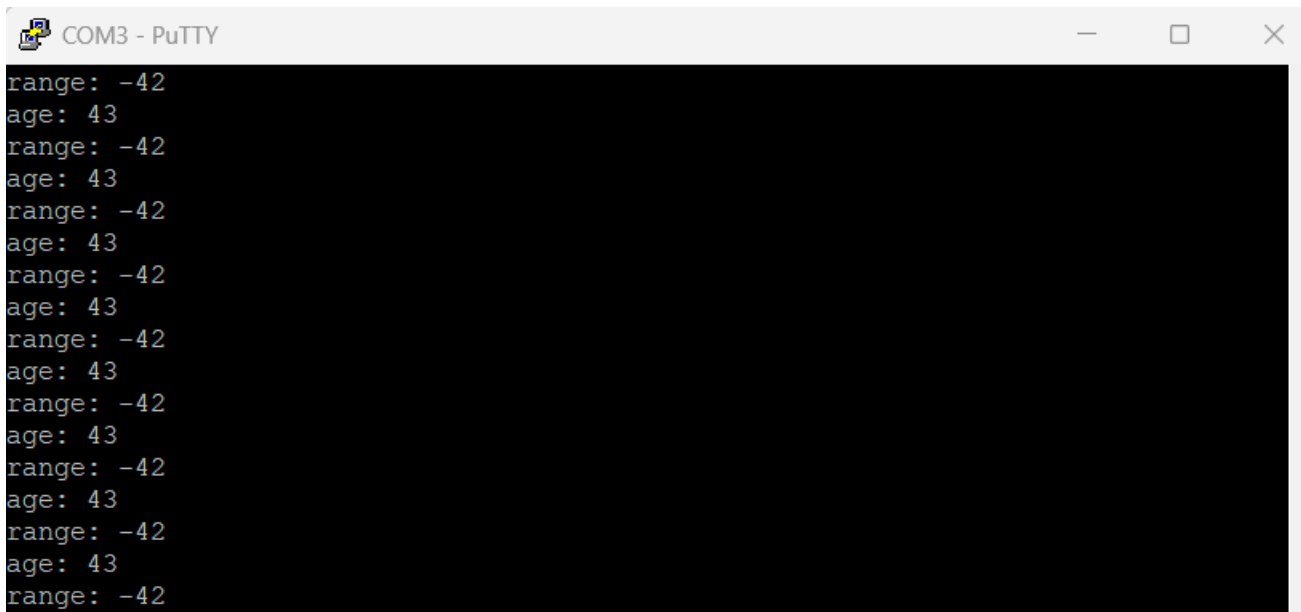

```
COM3 - PuTTY
range: -42
age: 43
range: -42
age: 43
range: -42
age: 43
range: -42
age: 43
range: -42
age: 43
range: -42
age: 43
range: -42
age: 43
range: -42
age: 43
range: -42
age: 43
range: -42
```

In our next lesson we will debug this.

Chapter 12: Debugging Integer Data Type

In this chapter we are going to discuss debugging the integer data type.

Run OpenOCD with the below config.

```
openocd -f interface/cmsis-dap.cfg -f target/rp2350.cfg -c "adapter speed 5000"
```

Open a new terminal and then run the following to launch our dynamic debugger called GDB.

```
arm-none-eabi-gdb build/0x000b_integer-data-type.bin
```

Once it loads, we need to target our remote server.

```
target remote :3333
```

We need to halt the currently running binary.

```
monitor reset halt
```

We need to review 46 instructions from main. We remember main is 0x10000234.

```
x/46i 0x10000234
0x10000234: push    {r4, r5, r6, lr}
0x10000236: bl      0x100030cc
0x1000023a: ldr     r3, [pc, #124] @ (0x100002b8)
0x1000023c: ldr     r2, [pc, #124] @ (0x100002bc)
0x1000023e: movs   r0, #16
0x10000240: lsls   r1, r0, #2
0x10000242: adds   r4, r3, r1
0x10000244: ldr     r5, [r4, #0]
0x10000246: bic.w  r5, r5, #384 @ 0x180
0x1000024a: orr.w  r5, r5, #64 @ 0x40
0x1000024e: str     r5, [r4, #0]
0x10000250: lsls   r1, r0, #3
0x10000252: adds   r4, r2, r1
0x10000254: ldr     r5, [r4, #0]
0x10000256: bic.w  r5, r5, #31
0x1000025a: orr.w  r5, r5, #5
0x1000025e: str     r5, [r4, #0]
0x10000260: mov    r4, r0
0x10000262: movs   r5, #1
0x10000264: mcrr   0, 4, r4, r5, cr4
0x10000268: adds   r0, #1
0x1000026a: cmp    r0, #20
0x1000026c: blt.n  0x10000240
0x1000026e: movs   r6, #16
0x10000270: mov    r4, r6
0x10000272: movs   r5, #1
0x10000274: mcrr   0, 4, r4, r5, cr0
0x10000278: mov.w  r0, #500 @ 0x1f4
0x1000027c: bl     0x10000d10
0x10000280: mov    r4, r6
0x10000282: movs   r5, #0
0x10000284: mcrr   0, 4, r4, r5, cr0
0x10000288: adds   r6, #1
0x1000028a: uxtb   r6, r6
0x1000028c: mov.w  r0, #500 @ 0x1f4
```

```
--Type <RET> for more, q to quit, c to continue without paging--
0x10000290: bl      0x10000d10
0x10000294: cmp     r6, #19
0x10000296: mov.w  r1, #43 @ 0x2b
0x1000029a: ldr    r0, [pc, #20] @ (0x100002b0)
0x1000029c: it     eq
0x1000029e: moveq  r6, #16
0x100002a0: bl     0x1000325c
0x100002a4: mvn.w  r1, #41 @ 0x29
0x100002a8: ldr    r0, [pc, #8] @ (0x100002b4)
0x100002aa: bl     0x1000325c
0x100002ae: b.n    0x10000270
```

I know the first thought might be one of feeling completely overwhelmed but let's take this step-by-step.

We first know that our source code is raw assembler so a good deal will match up however we are going to take this exact code and go step-by-step to better understand what is happening.

```
0x10000234: push   {r4, r5, r6, lr}
```

We begin by pushing these 4 registers onto the stack. We can break on 0x10000234 and review the stack before and after.

```
(gdb) b *0x10000234
```

```
Breakpoint 1 at 0x10000234
```

```
Note: automatically using hardware breakpoints for read-only addresses.
```

```
(gdb) c
```

```
Continuing.
```

```
Thread 1 "rp2350.cm0" hit Breakpoint 1, 0x10000234 in ?? ()
```

```
(gdb) x/4x $sp
```

```
0x20082000:      0x00000000      0x00000000      0x00000000      0x00000000
```

```
(gdb) x/i $pc
```

```
=> 0x10000234: push   {r4, r5, r6, lr}
```

We can see the stack is empty. We see we are about to execute the push statement so let's first review the values in the registers.

```
(gdb) i r
```

```
...
```

```
r4          0x100001d0      268435920
```

r5	0x88526891	-2007865199
r6	0x4f54710	83183376
r7	0x400e0014	1074659348
r8	0x43280035	1126694965
r9	0x0	0
r10	0x10000000	268435456
r11	0x62707361	1651536737
r12	0xa5024200	-1526578688
sp	0x20082000	0x20082000
lr	0x1000018f	268435855
...		

Let's step into and review the stack.

```
(gdb) si
```

```
0x10000236 in ?? ()
```

```
(gdb) x/4x $sp
```

```
0x20081ff0:    0x100001d0    0x88526891    0x04f54710    0x1000018f
```

```
(gdb) x/x $sp
```

```
0x20081ff0:    0x100001d0
```

```
(gdb) x/x $r4
```

```
0x100001d0:    0x2000062c
```

```
(gdb) x/x $sp+0x4
```

```
0x20081ff4:    0x88526891
```

```
(gdb) x/x $r5
```

```
0x88526891:    Cannot access memory at address 0x88526891
```

```
(gdb) x/x $sp+0x8
```

```
0x20081ff8:    0x04f54710
```

```
(gdb) x/x $r6
0x4f54710:      0x00000000
```

```
(gdb) x/x $sp+0xc
0x20081ffc:      0x1000018f
```

```
(gdb) x/x $lr
0x1000018f:      0x00478849
```

Here we can see clearly how the push works. Let's look at the next instruction is which will live within the program counter.

```
(gdb) x/i $pc
=> 0x10000236:  bl      0x100030cc
```

We know this is our call to `stdio_init_all`. We can simply step over it.

```
(gdb) b *0x1000023a
Breakpoint 2 at 0x1000023a
```

```
(gdb) c
Continuing.
```

Thread 1 "rp2350.cm0" hit Breakpoint 2, 0x1000023a in ?? ()

```
(gdb) x/i $pc
=> 0x1000023a:  ldr     r3, [pc, #124] @ (0x100002b8)
```

Let's examine what is located at the memory address of 0x100002b8.

```
(gdb) x/x 0x100002b8
0x100002b8:      0x40038000
```

This is the address of `PADS_BANK0_BASE` we saw in our source code.

As we step again, we see the value of the address of `IO_BANK0_GPIO0.ctrl` at the next instruction.

```
(gdb) si
0x1000023c in ?? ()
(gdb) x/x 0x100002bc
```

```
0x100002bc:      0x40028004
```

As we step again, we see GPIO16, our start pin, moved into r0.

```
(gdb) si
```

```
0x1000023e in ?? ()
```

```
(gdb) x/i $pc
```

```
=> 0x1000023e:  movs    r0, #16
```

The next set of instructions are part of our `init_loop`. This is an identical assembler match to our source code.

```
(gdb) si
```

```
0x10000240 in ?? ()
```

```
(gdb) x/18i $pc
```

```
=> 0x10000240:  lsls    r1, r0, #2
0x10000242:  adds    r4, r3, r1
0x10000244:  ldr     r5, [r4, #0]
0x10000246:  bic.w   r5, r5, #384    @ 0x180
0x1000024a:  orr.w   r5, r5, #64     @ 0x40
0x1000024e:  str     r5, [r4, #0]
0x10000250:  lsls    r1, r0, #3
0x10000252:  adds    r4, r2, r1
0x10000254:  ldr     r5, [r4, #0]
0x10000256:  bic.w   r5, r5, #31
0x1000025a:  orr.w   r5, r5, #5
0x1000025e:  str     r5, [r4, #0]
0x10000260:  mov     r4, r0
0x10000262:  movs    r5, #1
0x10000264:  mcrr    0, 4, r4, r5, cr4
0x10000268:  adds    r0, #1
```

```
0x1000026a: cmp      r0, #20
0x1000026c: blt.n   0x10000240
```

This loop is systematically initializing GPIO pins 16 through 19 on the RP2350 so they can be driven directly by the SIO block. For each pin, it first calculates the correct `PADS_BANK0` register offset and updates the pad configuration: clearing the output-disable and isolation bits, then enabling the input buffer. Next, it computes the `IO_BANK0` control register offset, clears the function-select field, and sets it to 5, which maps the pin to SIO rather than an alternate peripheral. With the pad and function configured, it then enables the pin's output driver using the `mcrr` instruction (a coprocessor write that acts like `gpio_set_oe(pin, 1)`). Finally, the loop increments the pin number and repeats until `r0` reaches 20, which ensures pins 16, 17, 18, and 19 are all configured before exiting.

Let's review the remaining code.

```
(gdb) b *0x1000026e
```

```
Breakpoint 3 at 0x1000026e
```

```
(gdb) c
```

```
Continuing.
```

```
Thread 1 "rp2350.cm0" hit Breakpoint 3, 0x1000026e in ?? ()
```

```
(gdb) x/23i $pc
```

```
=> 0x1000026e: movs    r6, #16
0x10000270: mov     r4, r6
0x10000272: movs    r5, #1
0x10000274: mcrr    0, 4, r4, r5, cr0
0x10000278: mov.w   r0, #500          @ 0x1f4
0x1000027c: bl      0x10000d10
0x10000280: mov     r4, r6
0x10000282: movs    r5, #0
0x10000284: mcrr    0, 4, r4, r5, cr0
0x10000288: adds   r6, #1
0x1000028a: uxtb   r6, r6
0x1000028c: mov.w   r0, #500          @ 0x1f4
0x10000290: bl      0x10000d10
```

```
0x10000294:  cmp    r6, #19
0x10000296:  mov.w  r1, #43 @ 0x2b
0x1000029a:  ldr    r0, [pc, #20] @ (0x100002b0)
0x1000029c:  it     eq
0x1000029e:  moveq  r6, #16
0x100002a0:  bl     0x1000325c
0x100002a4:  mvn.w  r1, #41 @ 0x29
0x100002a8:  ldr    r0, [pc, #8] @ (0x100002b4)
0x100002aa:  bl     0x1000325c
0x100002ae:  b.n   0x10000270
```

This corresponds to our `uint8_t pin = 16` and `while` loop.

```
uint8_t pin = 16;

while (1) {
    __asm volatile (
        "mov r4, %0\n"           // pin
        "movs r5, #0x01\n"      // bit 1; used for OUT/OE writes
        "mcrn p0, #4, r4, r5, c0\n" // gpioc_bit_out_put(16, 1)
        :
        : "r"(pin)
        : "r4","r5"
    );
    sleep_ms(500);

    __asm volatile (
        "mov r4, %0\n"           // pin
        "movs r5, #0\n"         // bit 0; used for OUT/OE writes
        "mcrn p0, #4, r4, r5, c0\n" // gpioc_bit_out_put(16, 0)
        :
        : "r"(pin)
        : "r4","r5"
    );
    sleep_ms(500);

    pin++;
    if (pin > 18) pin = 16;

    printf("age: %d\r\n", age);
    printf("range: %d\r\n", range);
}
}
```

Let's verify this by breaking at the following address and proving age is within the `r0` register.

```
(gdb) b *0x1000029a
```

```
Breakpoint 4 at 0x1000029a
```

```
(gdb) c
```

```
Continuing.
```

```
Thread 1 "rp2350.cm0" hit Breakpoint 4, 0x1000029a in ?? ()
```

```
(gdb) x/4i $pc
```

```
=> 0x1000029a: ldr    r0, [pc, #20] @ (0x100002b0)
```

```
0x1000029c: it    eq
```

```
0x1000029e: moveq r6, #16
```

```
0x100002a0: bl    0x1000325c
```

```
(gdb) si
0x1000029c in ?? ()
```

Here we can see within `r0` our string about to be passed to the `printf` function at `0x1000325c`.

```
(gdb) x/s $r0
0x10003618:      "age: %d\r\n"
```

Let's open up our PuTTY terminal or screen and see what happens when we break and continue to the next `printf` statement.

```
(gdb) b *0x100002a8
Breakpoint 5 at 0x100002a8
(gdb) c
Continuing.
Thread 1 "rp2350.cm0" hit Breakpoint 5, 0x100002a8 in ?? ()
```

We noticed the red LED flashed and we see `age: 43` within our terminal.



Let's review the last 3 instructions.

```
(gdb) x/3i $pc
=> 0x100002a8:  ldr    r0, [pc, #8]    @ (0x100002b4)
0x100002aa:  bl     0x1000325c
0x100002ae:  b.n   0x10000270
```

We know we have an unconditional break of `b.n 0x10000270` which will take us to the top of our loop and continue indefinitely. Let's step again and review `r0`.

```
(gdb) si
0x100002aa in ?? ()
(gdb) x/s $r0
0x10003624:      "range: %d\r\n"
```

We have verified our code now when we continue, we will see the green LED flash and see `range: -42` printed.



```
COM3 - PuTTY
age: 43
range: -42
```

In our next chapter we will hack this!

Chapter 13: Hacking Integer Data Type

In this chapter we are going to discuss hacking the integer data type.

Run OpenOCD with the below config.

```
openocd -f interface/cmsis-dap.cfg -f target/rp2350.cfg -c "adapter speed 5000"
```

Open a new terminal and then run the following to launch our dynamic debugger called GDB.

```
arm-none-eabi-gdb build/0x000b_integer-data-type.bin
```

Once it loads, we need to target our remote server.

```
target remote :3333
```

We need to halt the currently running binary.

```
monitor reset halt
```

We need to break at main and review 46 instructions from main. We remember main is 0x10000234.

```
(gdb) b *0x10000234
```

```
Breakpoint 1 at 0x10000234
```

Note: automatically using hardware breakpoints for read-only addresses.

```
(gdb) c
```

Continuing.

```
Thread 1 "rp2350.cm0" hit Breakpoint 1, 0x10000234 in ?? ()
```

```
(gdb) x/46i $pc
```

```
=> 0x10000234:  push    {r4, r5, r6, lr}
0x10000236:  bl      0x100030cc
0x1000023a:  ldr     r3, [pc, #124] @ (0x100002b8)
0x1000023c:  ldr     r2, [pc, #124] @ (0x100002bc)
0x1000023e:  movs   r0, #16
0x10000240:  lsls   r1, r0, #2
0x10000242:  adds   r4, r3, r1
0x10000244:  ldr    r5, [r4, #0]
0x10000246:  bic.w  r5, r5, #384 @ 0x180
0x1000024a:  orr.w  r5, r5, #64 @ 0x40
```

```

0x1000024e: str    r5, [r4, #0]
0x10000250: lsls   r1, r0, #3
0x10000252: adds   r4, r2, r1
0x10000254: ldr    r5, [r4, #0]
0x10000256: bic.w  r5, r5, #31
0x1000025a: orr.w  r5, r5, #5
0x1000025e: str    r5, [r4, #0]
0x10000260: mov    r4, r0
0x10000262: movs   r5, #1
0x10000264: mcrr   0, 4, r4, r5, cr4
0x10000268: adds   r0, #1
0x1000026a: cmp    r0, #20
0x1000026c: blt.n  0x10000240
0x1000026e: movs   r6, #16
0x10000270: mov    r4, r6
0x10000272: movs   r5, #1
0x10000274: mcrr   0, 4, r4, r5, cr0
0x10000278: mov.w  r0, #500      @ 0x1f4
0x1000027c: bl     0x10000d10
0x10000280: mov    r4, r6
0x10000282: movs   r5, #0
0x10000284: mcrr   0, 4, r4, r5, cr0
0x10000288: adds   r6, #1
0x1000028a: uxtb   r6, r6
0x1000028c: mov.w  r0, #500      @ 0x1f4
0x10000290: bl     0x10000d10

```

```

0x10000294:  cmp      r6, #19
0x10000296:  mov.w   r1, #43 @ 0x2b
0x1000029a:  ldr     r0, [pc, #20] @ (0x100002b0)
0x1000029c:  it      eq
0x1000029e:  moveq   r6, #16
0x100002a0:  bl      0x1000325c
0x100002a4:  mvn.w   r1, #41 @ 0x29
0x100002a8:  ldr     r0, [pc, #8] @ (0x100002b4)
0x100002aa:  bl      0x1000325c
0x100002ae:  b.n     0x10000270

```

Here we can hack 3 things, let's hack the starting LED, and the two integer values.

First, let's set breakpoints on the below.

```

0x1000026e:  movs    r6, #16
0x10000296:  mov.w   r1, #43 @ 0x2b
0x100002a4:  mvn.w   r1, #41 @ 0x29

```

```
(gdb) b *0x1000026e
```

Breakpoint 2 at 0x1000026e

```
(gdb) b *0x10000296
```

Breakpoint 3 at 0x10000296

```
(gdb) b *0x100002a4
```

Breakpoint 4 at 0x100002a4

```
(gdb) c
```

Continuing.

```
Thread 1 "rp2350.cm0" hit Breakpoint 2, 0x1000026e in ?? ()
```

1st hack, you will hack the green LED to light up.

```
(gdb) x/i $pc
```

```
=> 0x1000026e:  movs    r6, #16
```

```
(gdb) si
```

```
0x10000270 in ?? ()
```

```
(gdb) set $r6 = 17
```

```
(gdb) c
```

```
Continuing.
```

2nd hack, you will change the age to 44.

```
(gdb) x/i $pc
```

```
=> 0x10000296:  mov.w   r1, #43 @ 0x2b
```

```
(gdb) si
```

```
0x1000029a in ?? ()
```

```
(gdb) set $r1 = 44
```

```
(gdb) c
```

```
Continuing.
```

3rd hack, you will change the range to 50.

```
(gdb) x/i $pc
```

```
=> 0x100002a4:  mvn.w   r1, #41 @ 0x29
```

```
(gdb) si
```

```
0x100002a8 in ?? ()
```

```
(gdb) set $r1 = 50
```

```
(gdb) c
```

```
Continuing.
```

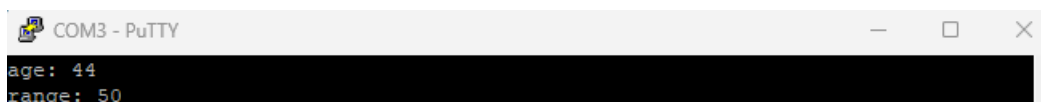

Boom! We hacked the LED to turn green when it should have been red, we hacked age to 44 when it should have

been 43 and we hacked range to 50.

In our next chapter we will discuss the floating-point data type.

Chapter 14: Floating-Point Data Type

In this chapter we are going to discuss the floating-point data type.

Let's open up our folder **0x000e_floating-point-data-type**.

Now let's review our **0x000e_floating-point-data-type.c** file as this is located in the main folder.

```
#include <stdio.h>
#include "pico/stdlib.h"

int main(void) {
    float fav_num = 42.5;

    stdio_init_all();

    while (true)
        printf("fav_num: %f\r\n", fav_num);
}
```

We start off with a `float fav_num = 42.5` which is a 32-bit float.

We then init our `stdio_init_all` for the purposes of our UART terminal interface.

We then simply echo `fav_num: 42.5` in the terminal.



The screenshot shows a PuTTY terminal window titled "COM3 - PuTTY". The terminal output consists of multiple lines of the text "fav_num: 42.500000", demonstrating that the program successfully prints the floating-point value to the terminal.

In our next lesson we will debug this.

Chapter 15: Debugging Floating-Point Data Type

In this chapter we are going to discuss debugging the floating-point data type.

Run OpenOCD with the below config.

```
openocd -f interface/cmsis-dap.cfg -f target/rp2350.cfg -c "adapter speed 5000"
```

Open a new terminal and then run the following to launch our dynamic debugger called GDB.

```
arm-none-eabi-gdb build/0x000b_integer-data-type.bin
```

Once it loads, we need to target our remote server.

```
target remote :3333
```

We need to halt the currently running binary.

```
monitor reset halt
```

```
(gdb) b *0x10000234
```

```
Breakpoint 1 at 0x10000234
```

Note: automatically using hardware breakpoints for read-only addresses.

```
(gdb) c
```

```
Continuing.
```

```
Thread 1 "rp2350.cm0" hit Breakpoint 1, 0x10000234 in ?? ()
```

```
(gdb) x/9i $pc
```

```
=> 0x10000234: push    {r3, r4, r5, lr}
      0x10000236: bl      0x10002f5c
      0x1000023a: movs   r4, #0
      0x1000023c: ldr    r5, [pc, #12] @ (0x1000024c)
      0x1000023e: mov    r2, r4
      0x10000240: mov    r3, r5
      0x10000242: ldr    r0, [pc, #12] @ (0x10000250)
      0x10000244: bl     0x100030ec
      0x10000248: b.n   0x1000023e
```

```
(gdb) b *0x10000244
```

```
Breakpoint 2 at 0x10000244
```

```
(gdb) c
```

Continuing.

```
Thread 1 "rp2350.cm0" hit Breakpoint 2, 0x10000244 in ?? ()
```

```
(gdb) x/i $pc
```

```
=> 0x10000244: bl      0x100030ec
```

Let's review what is inside `r2` and `r3`.

```
(gdb) i r $r2 $r3
```

```
r2          0x0          0
r3          0x40454000   1078280192
```

We see `r2` has the low word and `r3` has the high word so together `0x4045400000000000` = IEEE 754 encoding of 42.5.

```
(gdb) set $bits = ((long long)$r2 << 32) | $r3
```

```
(gdb) set {long long}0x20000000 = $bits
```

```
(gdb) x/gf 0x20000000
```

```
0x20000000: 42.5
```

When working with the RP2350 (Cortex M33), it is important to understand how floating point values are passed to functions like `printf`. In C, when you call `printf("%f", fav_num)` with a float, the compiler promotes that value to a double because `printf` is a variadic function. On ARM Cortex M, a double is 64 bits wide, and according to the procedure call standard, it is split across two 32-bit registers. In this case, the low 32 bits of the double go into one register and the high 32 bits go into another. For the value 42.5, the IEEE 754 double encoding is `0x4045400000000000`. That means one register holds `0x00000000` and the other holds `0x40454000`. If you look at only one register, the value appears meaningless, but together they form the correct double.

Inside GDB, you can reconstruct this double by combining the two registers. First, you shift the high word left by 32 bits and OR it with the low word to form a 64-bit integer. This gives you the raw bit pattern of the double. However, if you simply cast that integer to a double in GDB, it will convert the number's value rather than reinterpret its bits, which produces the wrong result. To force GDB to reinterpret the bits, you must store the 64-bit integer into memory and then examine that memory as a double. For example, by writing the packed value into a safe RAM location and using `x/gf` to display it, GDB will decode the bytes as a floating-point number. Doing this with the registers from the RP2350 shows the correct result: 42.5. This process demonstrates both how the ABI splits doubles across registers and how to use GDB to reassemble and verify them.

In our next chapter we will hack this!

Chapter 16: Hacking Floating-Point Data Type

In this chapter we are going to discuss hacking the floating-point data type.

Run OpenOCD with the below config.

```
openocd -f interface/cmsis-dap.cfg -f target/rp2350.cfg -c "adapter speed 5000"
```

Open a new terminal and then run the following to launch our dynamic debugger called GDB.

```
arm-none-eabi-gdb build/0x000b_integer-data-type.bin
```

Once it loads, we need to target our remote server.

```
target remote :3333
```

We need to halt the currently running binary.

```
monitor reset halt
```

```
(gdb) b *0x10000234
```

```
Breakpoint 1 at 0x10000234
```

Note: automatically using hardware breakpoints for read-only addresses.

```
(gdb) c
```

```
Continuing.
```

```
Thread 1 "rp2350.cm0" hit Breakpoint 1, 0x10000234 in ?? ()
```

```
(gdb) x/9i $pc
```

```
=> 0x10000234: push    {r3, r4, r5, lr}
      0x10000236: bl      0x10002f5c
      0x1000023a: movs   r4, #0
      0x1000023c: ldr    r5, [pc, #12] @ (0x1000024c)
      0x1000023e: mov    r2, r4
      0x10000240: mov    r3, r5
      0x10000242: ldr    r0, [pc, #12] @ (0x10000250)
      0x10000244: bl     0x100030ec
      0x10000248: b.n   0x1000023e
```

```
(gdb) b *0x10000244
```

```
Breakpoint 2 at 0x10000244
```

```
(gdb) c
```

Continuing.

```
Thread 1 "rp2350.cm0" hit Breakpoint 2, 0x10000244 in ?? ()
```

```
(gdb) x/i $pc
```

```
=> 0x10000244:  bl      0x100030ec
```

Let's review what is inside r2 and r3.

```
(gdb) i r $r2 $r3
```

```
r2          0x0          0
r3          0x40454000   1078280192
```

Let's say we want to hack 42.5 to be 43.375 so we need to change r3 to be 0x4045B000.

```
(gdb) i r $r2 $r3
```

```
r2          0x0          0
r3          0x40454000   1078280192
```

```
(gdb) set $r3 = 0x4045B000
```

```
(gdb) c
```

Continuing.

```
Thread 1 "rp2350.cm0" hit Breakpoint 2, 0x10000244 in ?? ()
```

We see 43.375 in the terminal.

```
(gdb) i r $r2 $r3
```

```
r2          0x0          0
r3          0x40454000   1078280192
```

```
(gdb) set $r3 = 0x4045C000
```

```
(gdb) c
```

Continuing.

```
Thread 1 "rp2350.cm0" hit Breakpoint 2, 0x10000244 in ?? ()
```

We now see 43.5 in the terminal.

When you look at the hexadecimal encodings of doubles, the difference between `0x4045B00000000000` and `0x4045C00000000000` comes down to the mantissa bits in the IEEE-754 format. Both numbers share the same sign bit (0 for positive) and the same exponent field (10000000100), which corresponds to an exponent of 5 after subtracting the bias of 1023. That exponent means the binary point is shifted so the number is expressed as something times 2^5 . The only part that changes between 43.375 and 43.5 is the mantissa, which encodes the fractional part of the number after normalization.

For **43.375**, the binary representation is `101011.011`. Normalized, that becomes `1.01011011 × 2^5`. The mantissa begins with `01011011...`, and when packed into the 52-bit fraction field, those bits line up to produce the hex sequence `...5B...`. That is why the high word of the double is `0x4045B000`. For **43.5**, the binary is `101011.1`, which normalizes to `1.010111 × 2^5`. The mantissa here is `010111...`, slightly larger than the previous case. When encoded, those bits produce the hex sequence `...5C...`, giving the high word `0x4045C000`. So, the difference between “B” and “C” in the hex is simply the mantissa incrementing by one step, moving the represented value from 43.375 to 43.5. This illustrates how tightly the mantissa bits map to fractional steps in the IEEE-754 encoding.

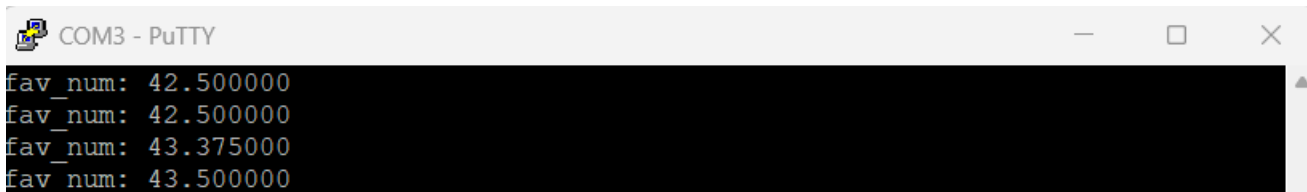

```
COM3 - PuTTY
fav_num: 42.500000
fav_num: 42.500000
fav_num: 43.375000
fav_num: 43.500000
```

In our next chapter we will discuss the double floating-point data type.

Chapter 17: Double Floating-Point Data Type

In this chapter we are going to discuss the double floating-point data type.

Let's open up our folder **0x0011_double-floating-point-data-type**.

Now let's review our **0x0011_double-floating-point-data-type.c** file as this is located in the main folder.

```
#include <stdio.h>
#include "pico/stdlib.h"

int main(void) {
    double fav_num = 42.52525;

    stdio_init_all();

    while (true)
        printf("fav_num: %lf\r\n", fav_num);
}
```

We start off with a `double fav_num = 42.52525` which is a 64-bit float.

We then init our `stdio_init_all` for the purposes of our UART terminal interface.

We then simply echo `fav_num: 42.52525` in the terminal.

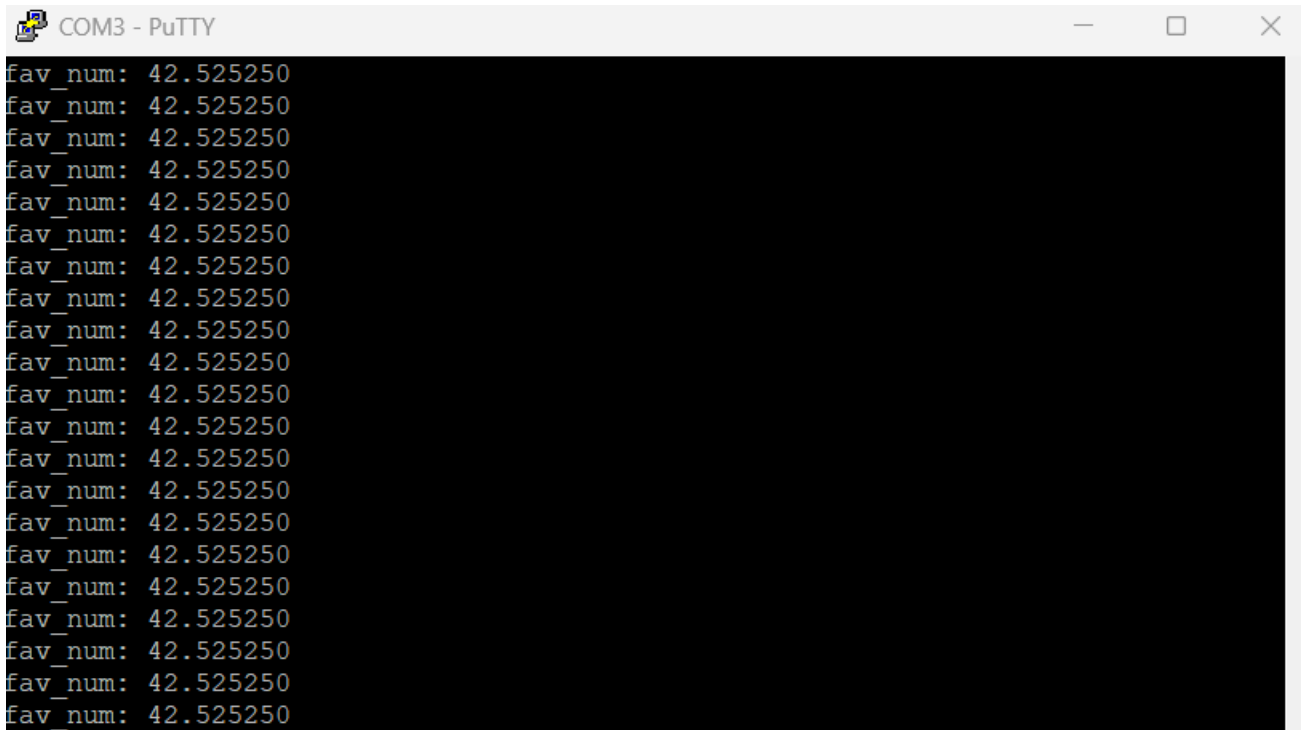

The image shows a screenshot of a PuTTY terminal window titled "COM3 - PuTTY". The terminal output consists of multiple lines of the text "fav_num: 42.525250", demonstrating the program's execution and output.

In our next lesson we will debug this.

Chapter 18: Debugging Double Floating-Point Data Type

In this chapter we are going to discuss debugging the double floating-point data type.

Run OpenOCD with the below config.

```
openocd -f interface/cmsis-dap.cfg -f target/rp2350.cfg -c "adapter speed 5000"
```

Open a new terminal and then run the following to launch our dynamic debugger called GDB.

```
arm-none-eabi-gdb build/0x0011_double-floating-point-data-type.bin
```

Once it loads, we need to target our remote server.

```
target remote :3333
```

We need to halt the currently running binary.

```
monitor reset halt
```

Let's debug.

```
(gdb) b *0x10000238
Breakpoint 1 at 0x10000238
Note: automatically using hardware breakpoints for read-only addresses.
(gdb) c
Continuing.
Thread 1 "rp2350.cm0" hit Breakpoint 1, 0x10000238 in ?? ()
(gdb) x/9i $pc
=> 0x10000238:  push    {r3, r4, r5, lr}
0x1000023a:  add     r5, pc, #24      @ (adr r5, 0x10000254)
0x1000023c:  ldrd   r4, r5, [r5]
0x10000240:  bl     0x10002f64
0x10000244:  mov    r2, r4
0x10000246:  mov    r3, r5
0x10000248:  ldr   r0, [pc, #4]     @ (0x10000250)
0x1000024a:  bl    0x100030f4
0x1000024e:  b.n   0x10000244
```

We literally have to follow the exact procedure in our last few chapters. If the below is confusing, please review the chapters related to the floating-point data type.

```
(gdb) b *0x1000024a
Breakpoint 2 at 0x1000024a
(gdb) c
Continuing.
Thread 1 "rp2350.cm0" hit Breakpoint 2, 0x1000024a in ?? ()
(gdb) i r $r2 $r3
r2          0x645a1cac          1683627180
r3          0x4045433b          1078281019
(gdb) set $bits = ((long long)$r2 << 32) | $r3
(gdb) set {long long}0x20000000 = $bits
(gdb) x/gf 0x20000000
0x20000000:    42.52525
(gdb) x/s *0x10000250
0x100034b0:    "fav_num: %lf\r\n"
```

Here we see the same `r2` and `r3`, both being 32-bit wide, each share the total of a single 64-bit value that when

formatted with `printf`, we see returns `42.52525`.

In our next chapter we will hack this!

Chapter 19: Hacking Double Floating-Point Data Type

In this chapter we are going to discuss hacking the double floating-point data type.

Run OpenOCD with the below config.

```
openocd -f interface/cmsis-dap.cfg -f target/rp2350.cfg -c "adapter speed 5000"
```

Open a new terminal and then run the following to launch our dynamic debugger called GDB.

```
arm-none-eabi-gdb build/0x0011_double-floating-point-data-type.bin
```

Once it loads, we need to target our remote server.

```
target remote :3333
```

We need to halt the currently running binary.

```
monitor reset halt
```

Let's hack.

```
(gdb) b *0x10000238
Breakpoint 1 at 0x10000238
Note: automatically using hardware breakpoints for read-only addresses.
(gdb) c
Continuing.
Thread 1 "rp2350.cm0" hit Breakpoint 1, 0x10000238 in ?? ()
(gdb) x/9i $pc
=> 0x10000238:  push    {r3, r4, r5, lr}
0x1000023a:  add     r5, pc, #24      @ (adr r5, 0x10000254)
0x1000023c:  ldrd   r4, r5, [r5]
0x10000240:  bl     0x10002f64
0x10000244:  mov    r2, r4
0x10000246:  mov    r3, r5
0x10000248:  ldr   r0, [pc, #4]     @ (0x10000250)
0x1000024a:  bl     0x100030f4
0x1000024e:  b.n   0x10000244
```

We literally have to follow the exact procedure in our last few chapters. If the below is confusing, please review the chapters related to the floating-point data type.

```
(gdb) b *0x1000024a
Breakpoint 2 at 0x1000024a
(gdb) c
Continuing.
Thread 1 "rp2350.cm0" hit Breakpoint 2, 0x1000024a in ?? ()
(gdb) i r $r2 $r3
r2                0x645a1cac          1683627180
r3                0x4045433b          1078281019
```

Let's have a little fun! We can figure out how to change our number to say, 43.52525. We can figure this out by doing the following.

```
(gdb) set {double}0x20000000 = 43.52525
(gdb) x/2wx 0x20000000
0x20000000:      0x4045c33b          0x645a1cac
```

So, we know r2 has the proper values for the values right of the decimal so we need to hack r3.

```
(gdb) set $r3 = 0x4045c33b
```

```
(gdb) c
```

```
Continuing.
```

```
Thread 1 "rp2350.cm0" hit Breakpoint 2, 0x1000024a in ?? ()
```

Let's review our PuTTY!



Boom! We hacked it!

In our next chapter we will discuss static variables.

Chapter 20: Static Variables

In this chapter we are going to discuss static variables and GPIO inputs.

Let's open up our folder **0x0014_static-variables**.

Now let's review our **0x0014_static-variables.c** file as this is located in the main folder.

```
#include <stdio.h>
#include "pico/stdlib.h"

int main(void) {
    stdio_init_all();

    const uint BUTTON_GPIO = 15;
    const uint LED_GPIO = 16;
    bool pressed = 0;

    gpio_init(BUTTON_GPIO);
    gpio_set_dir(BUTTON_GPIO, GPIO_IN);
    gpio_pull_up(BUTTON_GPIO);

    gpio_init(LED_GPIO);
    gpio_set_dir(LED_GPIO, GPIO_OUT);

    while (true) {
        uint8_t regular_fav_num = 42;
        static uint8_t static_fav_num = 42;

        printf("regular_fav_num: %d\r\n", regular_fav_num);
        printf("static_fav_num: %d\r\n", static_fav_num);

        regular_fav_num++;
        static_fav_num++;

        pressed = gpio_get(BUTTON_GPIO);
        gpio_put(LED_GPIO, pressed ? 0 : 1);
    }
}
```

We start off with two constants. The first being `BUTTON_GPIO` which is assigned to GPIO15 and the second is `LED_GPIO` which is assigned to GPIO16.

Additionally, we have a boolean called `pressed` which will store the value of our button press.

We have our `gpio_init` which we have seen before in great detail where it gets our `BUTTON_GPIO` setup for usage. We also set the direction as input and we have something new here where we use a `gpio_pull_up` turns on the internal pull-up so the pin is help at a logic HIGH when nothing is driving it. Without a pull resistor, the input is floating and will read random values.

We should use a pull-down resistor but for the sake of explanation, I wanted to drive it high so this forces us to

adjust our logic later in the code to account for this. The pull-up will normally keep the value high unless you press the button.

We then init our output which we have seen in great depth in earlier chapters.

The interesting thing is within our while loop as we have a `regular_fav_num` which is created as a `uint8_t`, unsigned 8-bit integer each time throughout the loop. This will literally redefine itself to 42 every pass through the loop so it will stay consistently 42 even though we increment it with `regular_fav_num++`.

The static variable however will live on the heap rather than the stack so its value will live through every reiteration of the while loop and will in-fact increment until it overflows to where it will start at 0 and work its way up to 255 and back to 0.

So... What is the heap vs the stack?

In our loop the regular variable is a stack variable where each time the loop iteration starts, a fresh `regular_fav_num` is created on the stack and initialized to 42, so incrementing it only affects that single instance before it gets destroyed at the end of the iteration and re-created again on the next pass and that's why it always appears to stay 42. The static variable is not allocated on the stack or the heap; it lives in static storage (a fixed data area in the program image or RAM reserved for globals/static variables) and is initialized once before the program runs. Because it persists across function calls and loop iterations, `static_fav_num++` updates the same memory location each time and the value accumulates until it overflows (for an 8-bit unsigned type it wraps from 255 back to 0). Static storage differs from heap allocation (`malloc/new`): heap objects are dynamically allocated and freed at runtime, while static storage is fixed for the program lifetime.

The final pair of lines reads the raw GPIO value for the button into `pressed` and then writes a corresponding logic level to the LED pin using a ternary expression. Because we enabled an internal pull-up, `gpio_get(BUTTON_GPIO)` returns 1 when the button is released and 0 when it is pressed, so the variable name `pressed` is a bit misleading (it holds the raw input, not a true boolean "pressed" flag). The ternary `pressed ? 0 : 1` maps that raw value to the LED output: if the input is non-zero (button released) it writes 0 to `LED_GPIO`, otherwise (button pressed) it writes 1 so the LED will be driven high when the button is actually pressed (assuming the LED is wired active-high). A clearer equivalent is `gpio_put(LED_GPIO, !gpio_get(BUTTON_GPIO))` and you can also invert the mapping or change wiring if you prefer the opposite behavior.

Let's open PuTTY and observe the behavior!

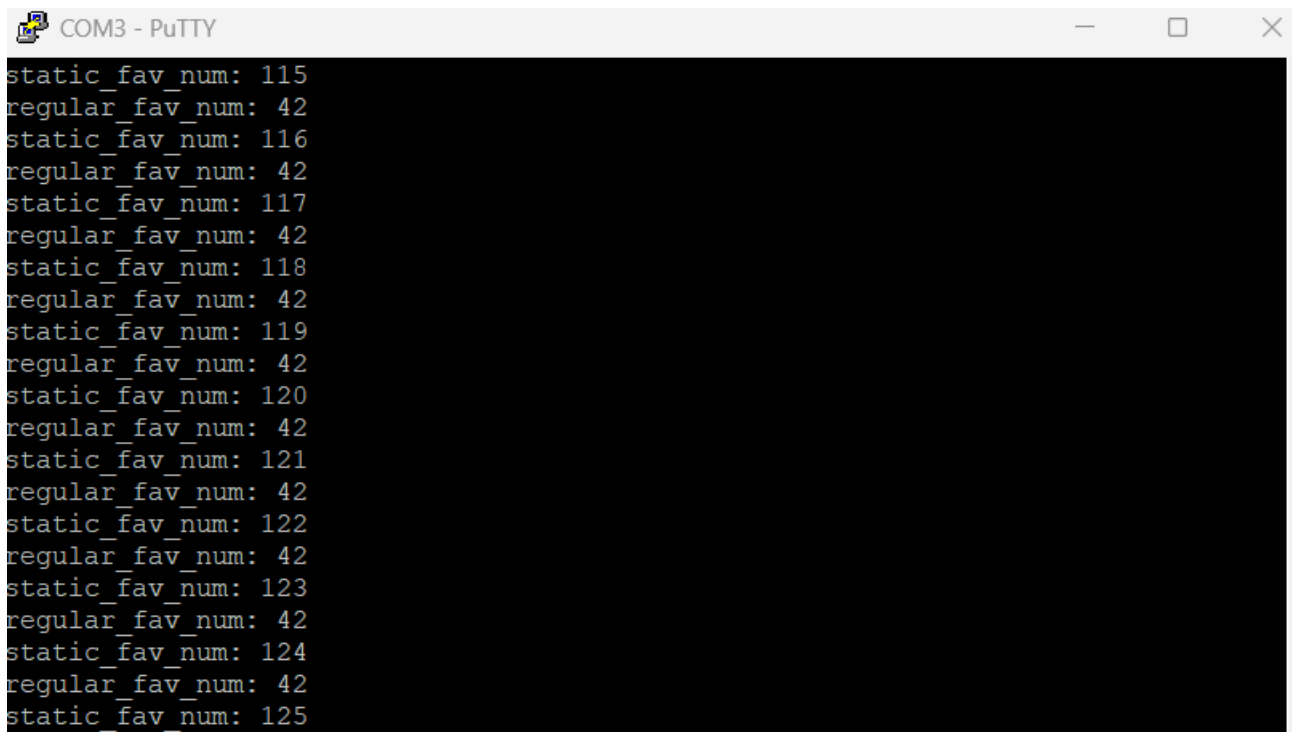

```
static_fav_num: 115
regular_fav_num: 42
static_fav_num: 116
regular_fav_num: 42
static_fav_num: 117
regular_fav_num: 42
static_fav_num: 118
regular_fav_num: 42
static_fav_num: 119
regular_fav_num: 42
static_fav_num: 120
regular_fav_num: 42
static_fav_num: 121
regular_fav_num: 42
static_fav_num: 122
regular_fav_num: 42
static_fav_num: 123
regular_fav_num: 42
static_fav_num: 124
regular_fav_num: 42
static_fav_num: 125
```

In our next lesson, we will debug this!

Chapter 21: Debugging Static Variables

In this chapter we are going to discuss debugging static variables and GPIO inputs.

Let's open up Ghidra and create a project for our **0x0014_static-variables**.

We have several chapters explaining how to create a project in Ghidra. At this stage you should be comfortable to do such.

```
***** ...
* FUNCTION ...
***** ...
undefined FUN_10000234 ()
undefined <UNASSIGNED> <RETURN>
FUN_10000234+1 XREF[1,1]: 1000018c (c), 1000018a (*)
FUN_10000234
10000234 10 b5 push {r4,lr}
10000236 02 f0 ed fe bl FUN_10003014 undefined FUN_10003014()
1000023a 0f 20 movs r0,#0xf
1000023c 00 f0 60 f8 bl FUN_10000300 undefined FUN_10000300()
10000240 0f 20 movs r0,#0xf
10000242 4f f0 00 03 mov.w r3,#0x0
10000246 43 ec 44 00 mcrr p0,0x4,r0,r3,cr4
1000024a 00 22 movs r2,#0x0
1000024c 01 21 movs r1,#0x1
1000024e 00 f0 43 f8 bl FUN_100002d8 undefined FUN_100002d8()
10000252 10 20 movs r0,#0x10
10000254 00 f0 54 f8 bl FUN_10000300 undefined FUN_10000300()
10000258 10 23 movs r3,#0x10
1000025a 4f f0 01 02 mov.w r2,#0x1
1000025e 42 ec 44 30 mcrr p0,0x4,r3,r2,cr4
10000262 0b 4c ldr r4,[DAT_10000290] = 200005A8h
LAB_10000264 XREF[1]: 1000028e (j)
10000264 2a 21 movs r1,#0x2a
10000266 0b 48 ldr r0=>s_regular_fav_num:_$d_10003560,[DAT_100002...= "regular_fav_num: $d\r\n"
= 10003560h
10000268 02 f0 9c ff bl FUN_100031a4 undefined FUN_100031a4()
1000026c 21 78 ldrb r1,[r4,#0x0]=>DAT_200005a8
1000026e 0a 48 ldr r0=>s_static_fav_num:_$d_10003578,[DAT_1000029...= "static_fav_num: $d\r\n"
= 10003578h
```

```
10000270 02 f0 98 ff bl FUN_100031a4 undefined FUN_100031a4()
10000274 4f f0 50 41 mov.w r1,#0xd0000000
10000278 23 78 ldrb r3,[r4,#0x0]=>DAT_200005a8
1000027a 10 22 movs r2,#0x10
1000027c 01 33 adds r3,#0x1
1000027e 23 70 strb r3,[r4,#0x0]=>DAT_200005a8
10000280 4b 68 ldr r3,[r1,#offset DAT_d0000004]
10000282 c3 f3 c0 33 ubfx r3,r3,#0xf,#0x1
10000286 83 f0 01 03 eor r3,r3,#0x1
1000028a 43 ec 40 20 mcrr p0,0x4,r2,r3,cr0
1000028e e9 e7 b LAB_10000264
```

Let's take our time and update these functions properly. If you are unclear on how to update function signatures please refer to earlier chapters.

Let's identify `main` which will be at `0x10000234`. This will be `int main(void)`.

Let's identify `stdio_init_all` which will be at `0x10003014`. This will be `bool stdio_init_all(void)`.

Let's identify `gpio_init` which will be at `0x1000023c` and `0x10000254`. This will be `void gpio_init(uint gpio)`.

For our next function, we need to understand about the concept of optimization. We programmed using a function called `gpio_pull_up` however it does not exist in our binary. When we drill-down into our binary, `gpio_pull_up` calls a function called `gpio_set_pulls` instead.

Let's identify `gpio_set_pulls` which will be at `0x1000024e`. This will be `void gpio_set_pulls(uint gpio, bool up, bool down)` instead.

Let's identify `printf` which will be at `0x10000268` and `0x10000270`. This will be `int printf(char *format, ...)` as `printf` is a variadic function which mean it can take an unlimited amount of arguments.

Within the while loop, the instruction `movs r1, #0x2a` loads the immediate value 42 into register `r1`. This corresponds to the initialization of the local variable `regular_fav_num = 42`. Immediately after, the `ldr r0, =s_regular_fav_num...` pulls in the address of the format string `"regular_fav_num: %d\r\n"`. With `r0` holding the format string and `r1` holding the integer value, the `bl printf` call matches the C statement `printf("regular_fav_num: %d\r\n", regular_fav_num)`.

Next, the compiler handles the static variable. Unlike the automatic local, which is reinitialized each loop iteration, the `static_fav_num` lives in the `.data` section at a fixed RAM address (`DAT_200005a8`). The instruction `ldrb r1, [r4, #0x0]` fetches its current value into `r1`. Then `ldr r0, =s_static_fav_num...` loads the format string `"static_fav_num: %d\r\n"`. Again, `bl printf` prints it. This matches the C line `printf("static_fav_num: %d\r\n", static_fav_num)`.

After printing, the code increments both counters. For the static variable, you can see `ldrb r3, [r4, #0x0]` to load it, `adds r3, #0x1` to increment, and `strb r3, [r4, #0x0]` to store it back. This is the compiled form of `static_fav_num++`. The automatic `regular_fav_num++` is optimized away in this loop because it's reinitialized to 42 every iteration, so its increment has no lasting effect, hence you don't see a store back to memory.

The bottom half of the loop corresponds to the GPIO logic. The instruction `mov.w r1, #0xd0000000` sets up a base address for a memory-mapped peripheral. Then `ldr r3, [r1, #offset DAT_d0000004]` reads from a register (likely the button input). The `ubfx r3, r3, #0xf, #0x1` extracts a single bit (bit 15), which is the button state. The `eor r3, r3, #0x1` flips it, implementing the ternary pressed ? 0 : 1. Finally, `mcrn p0, 0x4, r2, r3, cr0` is a coprocessor register write, which in this context is the compiler's way of emitting a store to the GPIO output register, effectively toggling the LED.

The unconditional branch `b LAB_10000264` at the end loops execution back to the start, reproducing the `while (true)` infinite loop. So, in summary: the assembly faithfully implements the C code by reinitializing a local variable, maintaining a static counter across iterations, printing both, and then reading a GPIO input to drive an LED output, all wrapped in an endless loop. The differences you notice, like the missing increment of the automatic variable, are the compiler's optimizations, since that increment has no observable effect.

Let's review our updated Ghidra.

```

*****
*                               FUNCTION                               *
*****
int __stdcall main(void)
int    r0:4    <RETURN>
main+1                                XREF[1,1]:  1000018c (c), 1000018a (*)
main
10000234 10 b5    push    {r4,lr}
10000236 02 f0 ed fe  bl     stdio_init_all      bool stdio_init_all(void)
1000023a 0f 20    movs    r0,#0xf
1000023c 00 f0 60 f8  bl     gpio_init        void gpio_init(uint gpio)
10000240 0f 20    movs    r0,#0xf
10000242 4f f0 00 03  mov.w   r3,#0x0
10000246 43 ec 44 00  mcrr   p0,0x4,r0,r3,cr4
1000024a 00 22    movs    r2,#0x0
1000024c 01 21    movs    r1,#0x1
1000024e 00 f0 43 f8  bl     gpio_set_pulls   void gpio_set_pulls(uint gpio, b ...
10000252 10 20    movs    r0,#0x10
10000254 00 f0 54 f8  bl     gpio_init        void gpio_init(uint gpio)
10000258 10 23    movs    r3,#0x10
1000025a 4f f0 01 02  mov.w   r2,#0x1
1000025e 42 ec 44 30  mcrr   p0,0x4,r3,r2,cr4
10000262 0b 4c    ldr     r4,[DAT_10000290] = 200005A8h

LAB_10000264                                XREF[1]:  1000028e (j)
10000264 2a 21    movs    r1,#0x2a
10000266 0b 48    ldr     r0=>s_regular_fav_num:_%d_10003560 ,[DAT_100002...= "regular_fav_num: %d\r\n"
= 10003560h
10000268 02 f0 9c ff  bl     printf            int printf(char * format, ...)
1000026c 21 78    ldrb   r1,[r4,#0x0]=>DAT_200005a8
1000026e 0a 48    ldr     r0=>s_static_fav_num:_%d_10003578 ,[DAT_1000029...= "static_fav_num: %d\r\n"
= 10003578h

10000270 02 f0 98 ff  bl     printf            int printf(char * format, ...)
10000274 4f f0 50 41  mov.w   r1,#0xd0000000
10000278 23 78    ldrb   r3,[r4,#0x0]=>DAT_200005a8
1000027a 10 22    movs    r2,#0x10
1000027c 01 33    adds   r3,#0x1
1000027e 23 70    strb   r3,[r4,#0x0]=>DAT_200005a8
10000280 4b 68    ldr     r3,[r1,#offset DAT_d0000004]
10000282 c3 f3 c0 33  ubfx   r3,r3,#0xf,#0x1
10000286 83 f0 01 03  eor    r3,r3,#0x1
1000028a 43 ec 40 20  mcrr   p0,0x4,r2,r3,cr0
1000028e e9 e7    b      LAB_10000264

```

In our next lesson, we will hack this!

